

---

## 开头语

---

衷心感谢您购买本公司产品！使用缝纫机之前，请认真阅读此说明书。本说明书介绍了缝纫机日常使用、维护与安全的有关注意事项。请您仔细加以保管，以便日后查阅。如产品规格或外观经过改良可能会与说明书略有不同，恕不另行通知。

---

## PROLOGUE

---

Thanking you for your purchase our products sincerely, please reading the manual book before operation, the book introduce some points how to operate, maintenance, and safe. Please keep it carefully for reading in the further; you will be not informed if the file has been revised. Please set sample as standard.

# 目 录

台板加工图	
Schematic diagram of the machine table.....	1
使用说明	
Operation Manual.....	3
零件样本	
Parts Book.....	22
1. 机壳分组件	
Arm Bed Components.....	23
2. 上轴、挑线分组件	
Main Shaft & Take-up Components.....	25
3. 针杆、夹线分组件.	
Needle Bar & Thread Tension Components.....	27
4. 压料分组件	
Presser Bar Components.....	29
5. 勾线分组件	
Hook Driving Shaft Components.....	31
6. 送料分组件	
Feed Mechanism Components.....	33
7. 送料调节分组件	
Feed Regulatig Components.....	35
8. 润滑分组件	
Lubrication Components.....	37
9. 油盘、膝提压脚分组件	
Oil Reservoir & Knee Lifter Components.....	39
10. 机头附件(1)	
Machine Head Accessories(1).....	41
机头附件(2)	
Machine Head Accessories(2).....	43
11. 机架、台板、电器分组件	
Machine Stand、Table & Electric Appliance Components.....	45
厚料用	
For Heavy Weight Materials.....	47

# 台板加工图 (内销)

## Schematic diagram of the machine table (domestic)

请参照下图进行台板的加工。

Cut the table referring to the diagram.

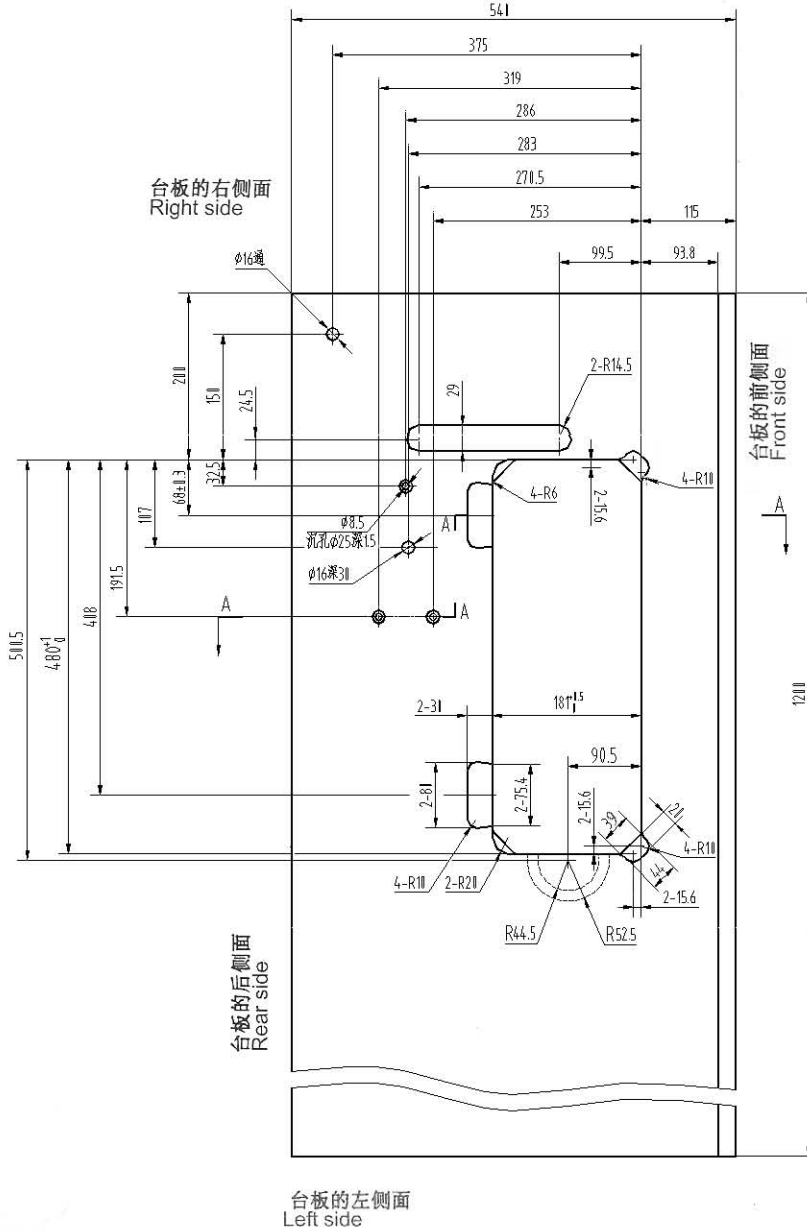

标准尺寸  
Standard dimension

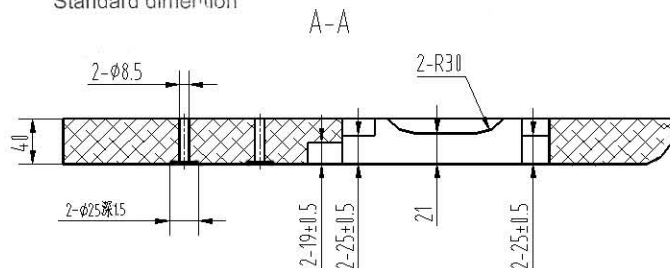

# 台板加工图 (外销)

## Schematic diagram of the machine table (export)

请参照下图进行台板的加工。

Cut the table referring to the diagram.

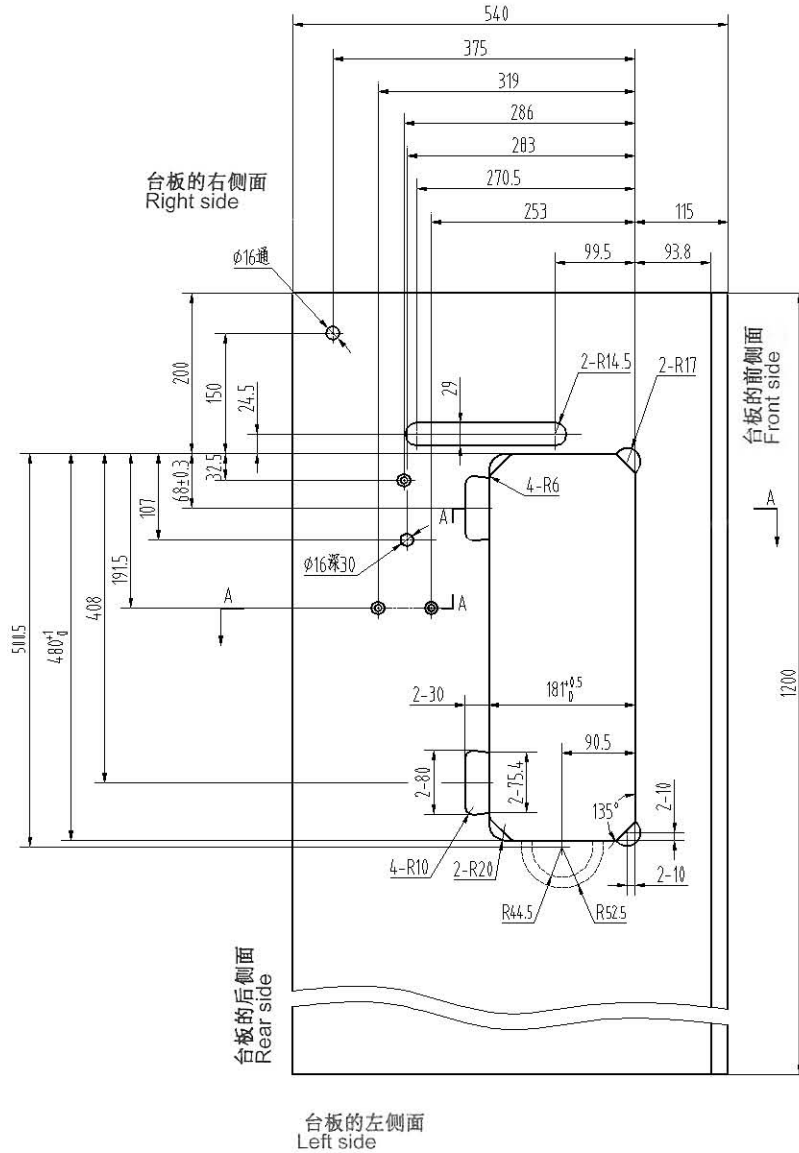

标准尺寸  
Standard dimension

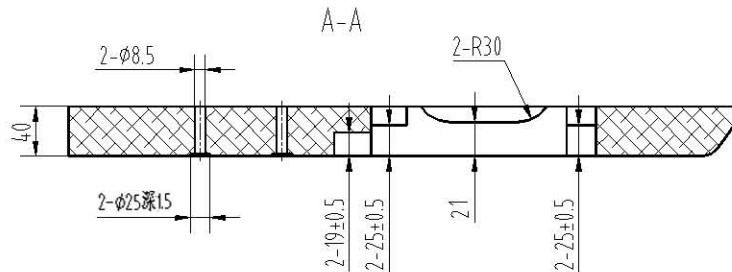

# 使用说明

## Operation Manual

### 开车前的注意事项: BEFORE OPERATION

1. 油盘内未加油绝不能开车。
  2. 机器运转时，从上轮外侧看转向应为逆时针方向。注意，不能倒转。
  3. 在第一月中，不要选用大尺寸的电动机皮带轮。
  4. 确认电动机标牌上标电压及相位是否正确。
1. Never operate the machine unless its oil pan has been filled with oil.
  2. After setting up the machine, check the direction of motor rotation. To check it, turn the handwheel by hand to bring the needle down, and turn the power switch ON while observing the handwheel. (The handwheel should turn counterclockwise as observed from the handwheel side.)
  3. Do not use a larger motor pulley for the first one month.
  4. Confirm that the voltage and phase (single or 3-phase) are correct by checking them against the ratings shown on the motor nameplate.

### 使用注意事项: OPERATION PRECAUTIONS

1. 接通电源开关或机器运转时，请勿将手放到针的下部。
  2. 机器运转时，请勿将手指伸入挑线杆护罩内。
  3. 机头翻动及拆三角皮带时，一定要切断电机开关。
  4. 操作者离开机器时，必须切断电源。
  5. 机器运转期间，注意不允许任何人的头或手以及任何东西靠近上轮“V”形皮带、绕线轮和电动机。
  6. 装拆皮带罩、防护罩、或者其它保护装置时，请勿开动机器。
  7. 不要用香蕉水等油漆稀释剂擦洗机头表面。
1. Keep your hands away from the needle when you turn the power switch ON or while the machine is operating.
  2. Do not put your fingers into the thread take-up cover while the machine is operating.
  3. Be sure to turn the power switch OFF before tilting the machine head or removing the V belt.
  4. When an operator leaves from the machine, make sure to turn off the power.
  5. During operation, be careful not to allow your or any other person's head or hands to come close to the handwheel, V belt, bobbin winder or motor. Also, do not place anything close to them. Doing so may be dangerous.
  6. If your machine is provided with a belt cover, finger guard or any other protectors, do not operate your machine with any of them removed.
  7. Don't clean the face of machine head with thinner.

## 1. 机器的安装(图 1、图 2、图 3、图 4)

## 1. INSTALLATION (Fig.1, Fig.2, Fig.3, Fig.4)

### \* 油盘安装:

- 1) 油盘应搁在工作台凸槽四角。
- 2) 如图所示, 将两只油盘支座①用油盘座钉②固定在 A 一边 (朝操作者一边), 将两只油盘座垫③用油盘座钉②固定在 B 一边 (用机头连接钩接合一边), 最后把油盘④放在其上。(图 1、图 2)
- 3) 将机头连接钩①放入底板孔内, 与台板的机头连接钩座②相嵌合, 再将机头放到四只角的机头座垫③上。(图 3、图 4)

### \*Installing the oil pan

- 1) The oil pan should rest on the four corners of the machine table groove.
- 2) Fix two rubber seats ① on side A (operator's side) using nails ② as illustrated above. Fix two cushion seats ③ on side B (hinged side) using nails ②. Then place oil pan ④ on the fixed seats. (Fig.1, Fig.2)
- 3) Fit hinge ① into the opening in the machine bed, and fit the machine head to table rubber hinge ② before placing the machine head on cushions ③ on the four corners. (Fig.3, Fig.4)

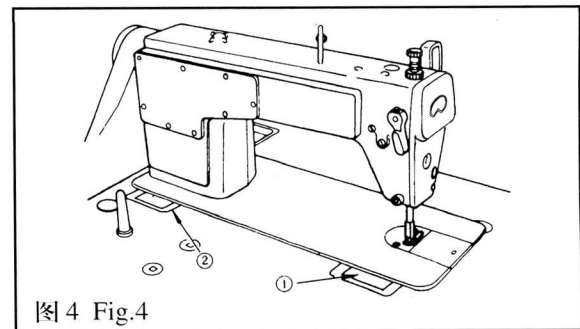
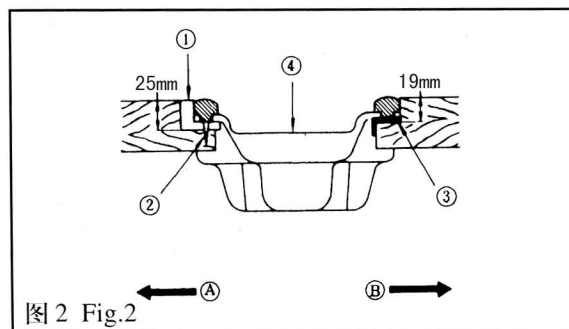
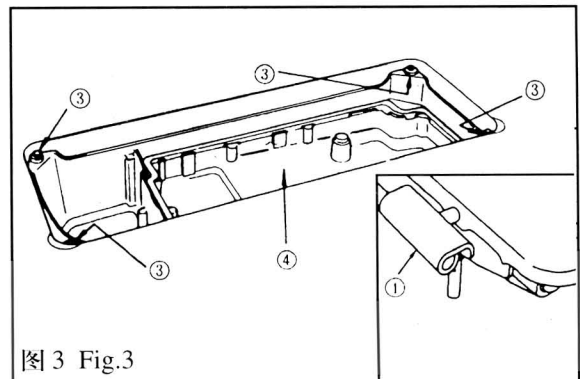
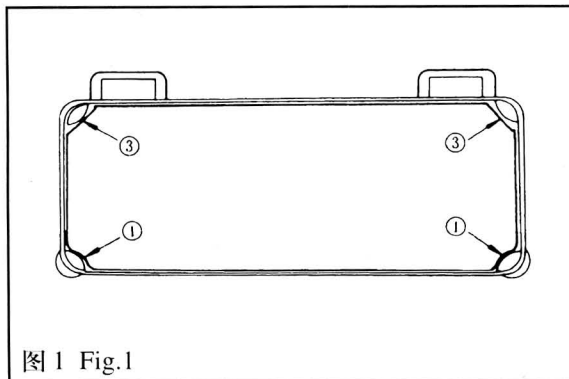

## 2. 机器的润滑(图 5、图 6)

### 2. LUBRICATION (Fig.5, Fig.6)

#### 1. 润滑须知:(图 5)

##### \* 开车前:

- 1) 向油盘①内加缝纫机油(10号白油)至 HIGH 记号部位 A。(图 5)
- 2) 当油面低于 LOW 记号 B, 应再加油。
- 3) 加油后, 开动机器, 应看到油液飞溅到油窗②上, 说明润滑正常。
- 4) 至于飞溅的油量多少与总润滑油量多少无关。

##### \* 注意:

使用新机器或者长期未使用过的机器时, 应在每分钟 3000~3500 针的状态下使机器进行十分钟左右的适应性运转。

#### 2. 面部油量采用油线渗油的方法:(图 6)

##### 1. Information on lubrication (Fig.5)

##### \* Before starting the machine

- 1) Fill oil pan ① with sewing machine oil (10 white oil) up to HIGH mark A.
- 2) When the oil level lowers below LOW mark B, refill the oil pan with the specified oil.
- 3) When you operate the machine after lubrication, you will see splashing oil through oil sight window ② if the lubrication is adequate.
- 4) Note that the amount of the splashing oil is unrelated to the amount of the lubricating oil.

##### \*Precaution

**When you first operate your machine after set up or after an extended period of disuse, run your machine at 3,000 s.p.m. to 3,500 s.p.m. for about 10 minutes for the purpose of break-in.**

2. The amount of oil which supplied to the face plate parts can use oil wick to seep oil (Fig.6)



图5 Fig.5



图6 Fig.6

### 3. 旋梭油量的调节(图7、图8、图9)

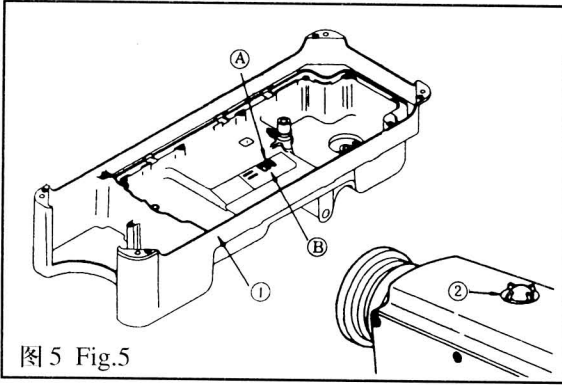
### 3. ADJUSTING THE AMOUNT OF OIL SUPPLIED TO THE HOOK (Fig.7, Fig.8, Fig.9)

1)未使用的机器应进行约3分钟的空转(适当的断续运转)。(图7)

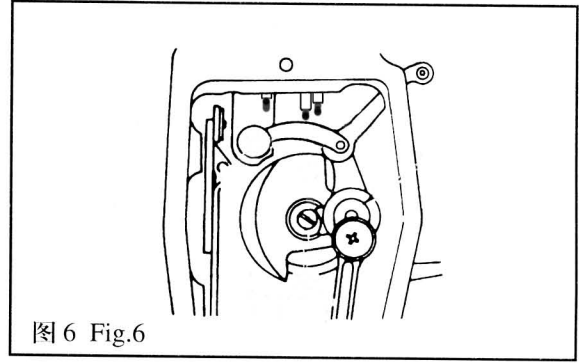
2)油量纸必须在机器运转状态下插入。

3)确认油盘内的油面高度处在HIGH和LOW范围内。

4)油量确认时间需5秒钟(请用秒表计时)。

\* 适量的油量标样:(图8)

1)下图标样根据不同的缝制工序需进行增或减的微调整,但应注意不要增加或减少得过多。

\* 油量过少会引起旋梭发热,油量过多会油污缝料。

2)用油量纸试用三次,当纸上油迹不发生变化时,就不需再调节了。

\* 调节旋梭油量:(图9)

1)将下轴前轴套上的油量调节螺钉朝+方向A转动时,油量将增大。当油量调节螺钉朝-方向B转动时,油量将减小。

2)调整后应进行约30秒钟的空转,以确认油量的状态。

1)After cooling, the machine may be idling for three minutes (operating continued properly). (Fig 7)

2)The amount of oil confirmed paper must be inserted in the state when the machine is operating.

3)Oil in the oil pan is confirmed within HIGH and LOW.

4)The amount of oil confirmed is for five seconds (please use the clock with the second)

**\*The proper amount of oil manual (Fig 8)**

1)The amount of oil can be adjusted according to the different sewing process but it must be suitable amount.

**\* Otherwise the hook wil generate heat or the sewing material will be contaminated.**

2)Use the amount of confirmed paper for three times to observe the amount of oil. Adjust the screw until the mark on the paper hasn't changed.



**\*Adjusting the amount of oil supplied to the hook (Fig 9)**

- 1) More oil is supplied as oil amount adjust screw mounted on the hook driving shaft is turned toward + in direction A. As the oil amount adjust screw is turned toward - in direction B, the amount of oil supplied will be decreased.
- 2) After adjusted, the machine must be idling for thirty seconds. It can be confirmed the state of oil supplied.

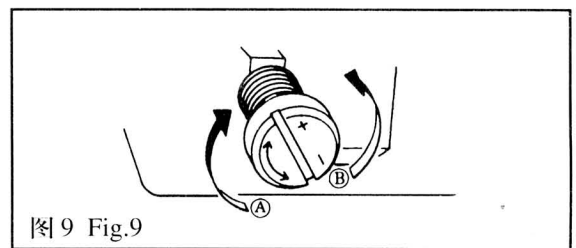
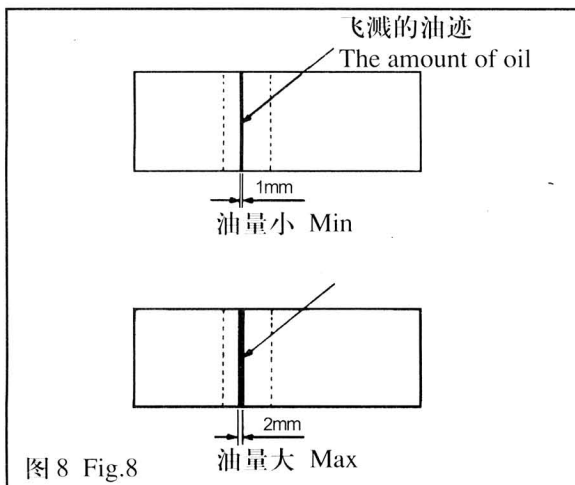
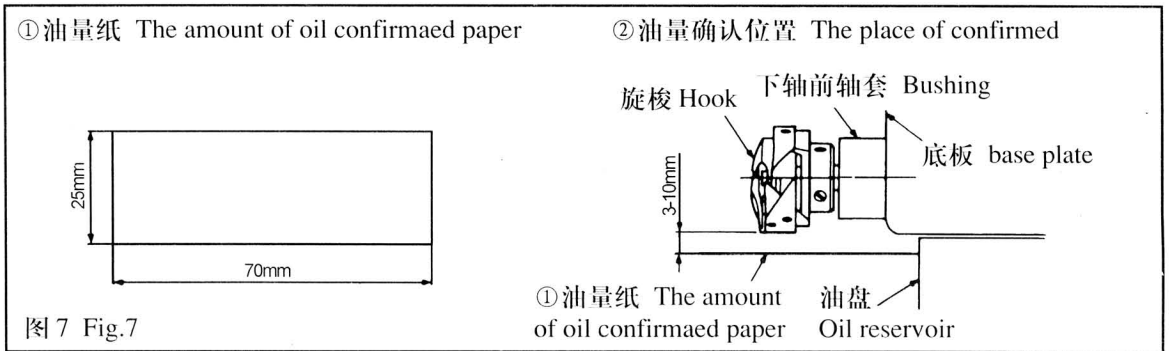

**4. 机针的装法 (图 10)**  
**4. ATTACHING THE NEEDLE (Fig.10)**

- \* 在装机针前，必须切断电动机电源。
- 标准用针为 DB × 1#14。机针有各种编号，根据所用线的粗细和缝料来选择适当的机针。
- 1) 转动上轮使针杆上升到最高位置。
  - 2) 旋松支针螺钉②，使机针的凹弧部分 A 正对右方向 B。
  - 3) 将机针朝箭头方向插入针孔的底部，直至插不进为止。
  - 4) 旋紧支针螺钉②。
  - 5) 务必使机针的长槽 C 正对左方向 D。

**\*Turn the motor power OFF before starting to attach the needle.**

A needle of DB × 1#14 should be used. Select a proper needle size according to the count of thread and the type of material used.

- 1) Turn the handwheel until the needle bar reaches the highest point of its stroke.
- 2) Loosen screw ②, and hold needle ① with its indented part A facing exactly to the right in direction B.
- 3) Insert the needle in the direction of the arrow until it will go no further.
- 4) Securely tighten screw ②.
- 5) Check that long groove C of the needle is facing exactly to the left in direction D.



图10 Fig 10

### 5. 梭心的装法(图 11)

### 5. SETTING THE BOBBIN INTO THE BOBBIN CASE (Fig. 11)

- 1) 拿住梭子，将梭心装入梭子内。
  - 2) 把线从梭子上的线槽 A 中穿过，朝 B 方向拉出。这样，线通过夹线簧下从线孔 B 处引出。
  - 3) 拉底线 C 时，梭心应按箭头方向转动。
- 1) Hold the bobbin in a way that the thread open end is directed to the left as observed from you, and set the bobbin into the bobbin case.
  - 2) Pass the thread through thread slit A, and pull the thread in direction B. By so doing, the thread will pass under the tension spring and come out from notch B.
  - 3) Check that the bobbin rotates in the direction of the arrow when thread C is pulled.

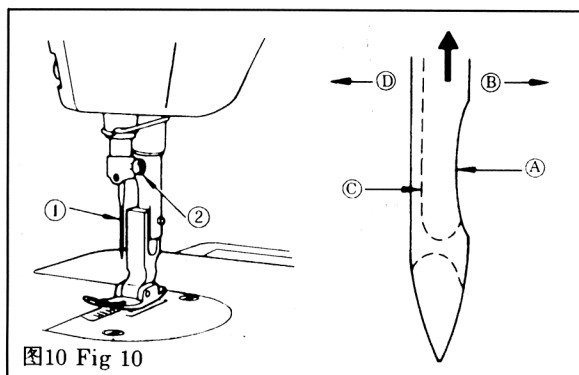

图11 Fig.11

## 6. 面线的穿法(图 12)

## 6.THREADING THE MACHINE HEAD (Fig.12)

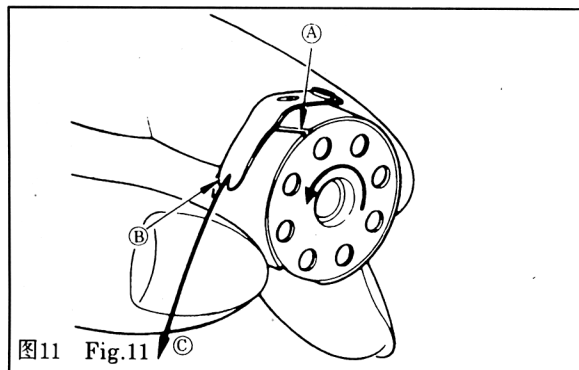
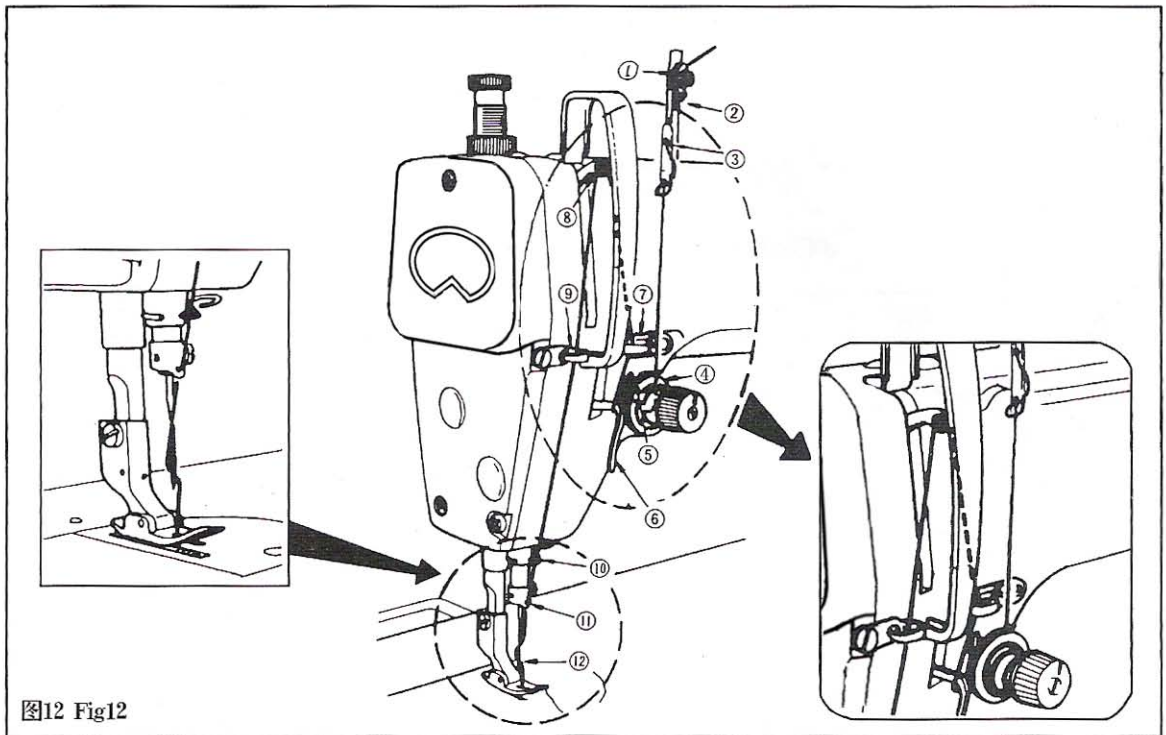

## 7. 针距的调节(图 13)

## 7. ADJUSTING THE STITCH LENGTH (Fig.13)

1)将送料距旋钮①朝箭头方向转动,旋至所需数字对准机壳上的刻点A。

2)旋钮上的刻度数用毫米表示。

3)当你想缩短线迹长度时,把倒送料扳手②朝箭头方向压的同时,转动送料距旋钮。

1) Turn stitch length dial ① in the direction of the arrow, and align the desired number to marker dot A on the machine arm.

2) The dial calibration is in millimeters.

3) When you want to decrease the stitch length, turn stitch length dial ① while pressing feed lever ② in the direction of the arrow.



图13 Fig. 13

## 8. 缝线张力(图 14)

## 8. THREAD TENSION (Fig.14)

### 1. 面线张力的调节:

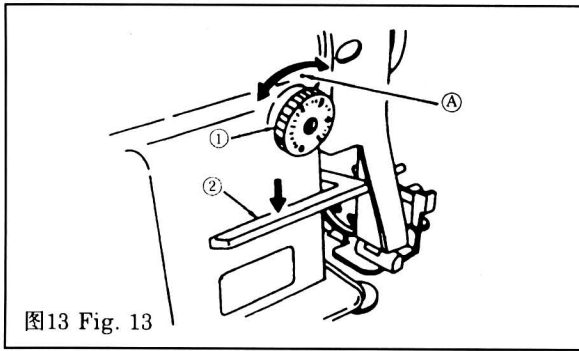
- 1) 根据不同的缝制条件，用夹线螺母来调整面线张力。
- 2) 若把螺母①按顺时针方向（即 A 方向）转动时，面线张力将增大。
- 3) 若把螺母①按逆时针方向（即 B 方向）转动时，面线张力将减小。

### 2. 底线张力的调节:

- 1) 将夹线螺钉②朝顺时针方向（即 C 方向）转动时，底线张力将增大。
- 2) 将夹线螺钉②朝逆时针方向（即 D 方向）转动时，底线张力将减小。

### 1. Adjusting the needle thread tension

- 1) Adjust the needle thread tension using tension adjust nut ① according to the sewing specifications.
- 2) As you turn nut ① clockwise (in direction A), the needle thread tension will increase.
- 3) As you turn nut ① counterclockwise (in direction B), the tension will decrease.

### 2. Adjusting the bobbin thread tension

- 1) As you turn tension adjust screw ② clockwise (in direction C), the bobbin thread tension will increase.
- 2) As you turn screw ② counterclockwise (in direction D), the bobbin thread tension will decrease.



图14 Fig. 14

## 9. 挑线簧(图 15)

## 9. THREAD TAKE UP SPRING (Fig.15)

### 1. 改变挑线簧①的摆动量:

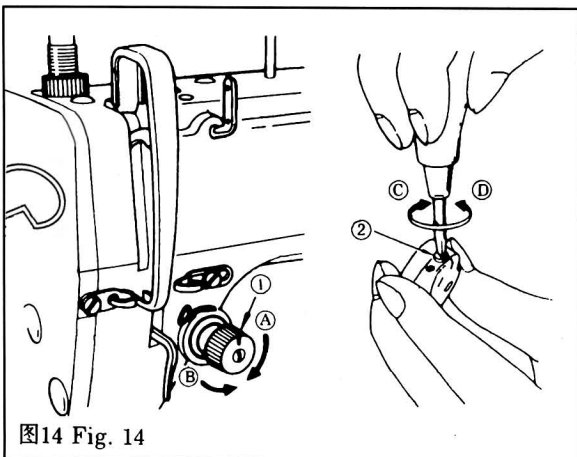
- 1) 旋松定位螺钉②。
- 2) 把夹线螺钉③朝顺时针方向 (即 A 方向) 转动时, 挑线簧的摆动量将增大。
- 3) 把夹线螺钉朝逆时针方向 (即 B 方向) 转动时, 挑线簧的摆动量将减小。

### 2. 改变挑线簧①的张力:

- 1) 旋松定位螺钉②, 取出夹线器 (组件) ⑤。
- 2) 旋松定位螺钉④, 并转动夹线螺钉③。
- 3) 把夹线螺钉③朝顺时针方向 (即 A 方向) 转动时, 挑线簧的张力将增大。
- 4) 把夹线螺钉③朝逆时针方向 (即 B 方向) 转动时, 挑线簧的张力将减小。

### 1. Changing the stroke of thread take-up spring ①

- 1) Loosen setscrew ② .
- 2) As you turn tension post ③ clockwise (in direction A), the stroke of the thread take-up spring will be increased.
- 3) As you turn the knob counterclockwise (in direction B), the stroke will be decreased.

### 2. Changing the pressure of thred take-up spring ①

- 1) Loosen setscrew ② , and take out tension asm ⑤ .
- 2) Loosen setscrew ④ , and remove tension post ③ .
- 3) As you turn tension post ③ clockwise (in direction A), the pressure will be increased.
- 4) As you turn the post counterclockwise (in direction B), the pressure will be decreased.

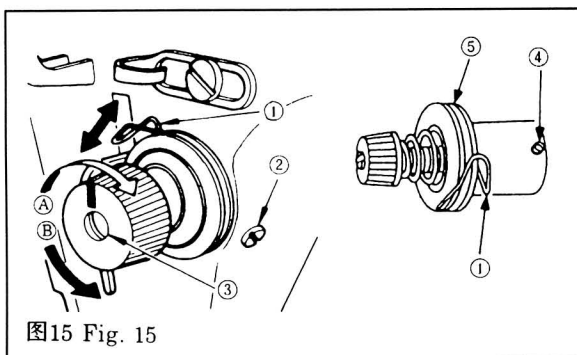

## 10. 压脚扳手(图 16)

## 10. HAND LIFTER (Fig.16)

- 1) 停车后, 将压脚扳手①朝 A 方向转动, 使压脚抬起。
- 2) 压脚的抬起量约 5.5 毫米。
- 3) 当压脚扳手①朝 B 方向转动时, 压脚将放回原来位置。
- 4) 对膝提压脚而言, 压脚的抬起量约为 10 毫米, 最大抬起量约为 13 毫米。

- 1) To stop the machine with its presserfoot up, turn hand lifter ① in direction A.
- 2) The presser foot will go up about 5.5 mm and stop.
- 3) The presser foot will go back to its original position when hand lifter ① is turned down in direction B.
- 4) Using the knee lifter, you can get the standard presser foot lift of about 10 mm and a maximum lift of about 13 mm.



图 16 Fig.16

### 11. 压脚压力的调节(图 17)

### 11. PRESSER FOOT PRESSURE (Fig.17)

- 1) 旋松调压螺母②。顺向（即 A 方向）转动压脚调节螺钉，压力将增强。
  - 2) 逆向（即 B 方向）转动压脚调节螺钉。压力将减弱。
  - 3) 调节后，旋紧调压螺母②。
  - 4) 对一般布料而言，压脚调节螺钉的标准高度为 29~32 毫米(5 公斤)左右。
- 1) Loosen nut ② . As you turn presser spring regulator ① clockwise (in direction A), the presser foot pressure will be increased.
  - 2) As you turn the presser spring regulator counterclockwise (in direction B), the pressure will be decreased.
  - 3) After adjustment, tighten nut ② .
  - 4) For general fabrics, the standard height of the presser spring regulator is 29 to 32 mm (5kg).

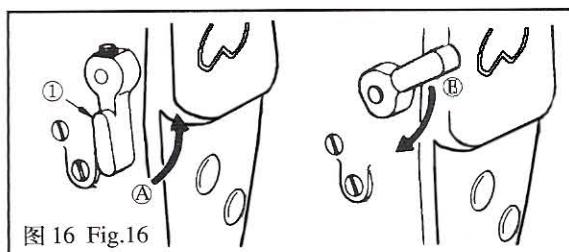

图 17 Fig.17

## 12. 送料相位的调节(图 18)

## 12. ADJUSTING THE FEED TIMING (Fig.18)

- 1) 旋松送料偏心凸轮①上的定位螺钉②和③, 将送料偏心凸轮①调到适当的位置, 然后拧紧定位螺钉。
- 2) 在标准相位情况下, 当送料牙从针板面下降时, 送料牙上端、针孔上端和针板上端面对齐。
- 3) 为了防止缝料的潜移, 要加快送料相位, 可将送料偏心轮朝箭头方向调整。
- 4) 为了增大线迹的紧密度, 要减慢送料相位, 可将送料偏心轮朝箭头反方向移动。

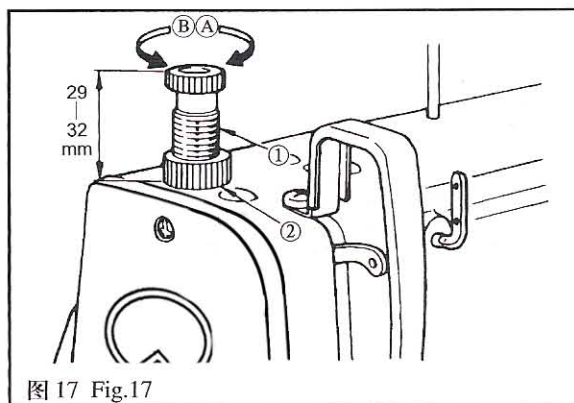
\*注意:

若送料偏心轮移动过多, 则会引起断针。

- 1) Loosen two setscrews ② and ③ on feed eccentric cam ①, properly position the eccentric cam. Then retighten the setscrews.
- 2) To obtain the standard feed timing, when when the feed dog is dropping from throat plate, align the top of the feed dog with the top of the hole on the needle and the top of the throat plate.
- 3) To advance the feed timing in order to prevent uneven material feed, move the feed eccentric cam in the direction of the arrow.
- 4) To delay the feed timing in order to increase stitch tightness, move the feed eccentric cam in the opposite direction from the arrow.

**\*If moving the feed eccentric cam to far, the needle will be break.**

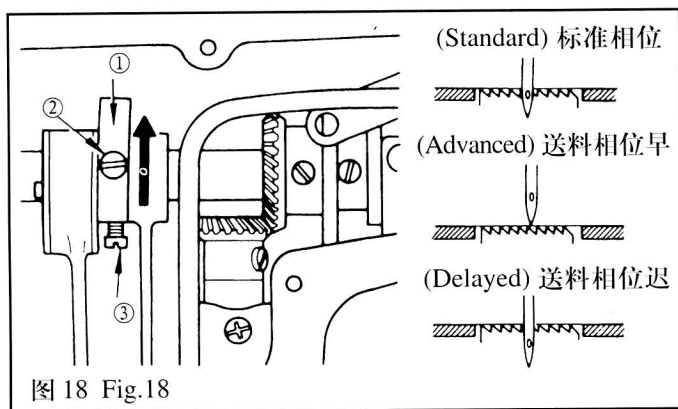

### 13. 送料牙的高度(图19)

### 13. HEIGHT OF THE FEED DOG (Fig. 19)

- 1) 送料牙应比针板高出 0.8 mm。厚料机型为 1mm。
- 2) 在缝薄料的情况下，如果送料牙过分凸出会导致缝料起皱。(推荐送料牙突出量：0.6-0.7 毫米)
- 3) 调节送料牙的高度：
  - ① 旋松抬牙叉形曲柄①的紧固螺钉②。
  - ② 上下移动牙架进行调节。
  - ③ 旋紧曲柄螺钉②。

**\* 注意：**

若曲柄螺钉紧固压力太小，会使抬牙叉形曲柄磨损。

a 送料牙      b 针板

- 1) The feed dog is factory - adjusted so that it just out from the throat plate surface 0.8 mm. For the heavy weight, 1mm.
- 2) If the feed dog juts out too much, puckering may result when sewing light-weight materials. (Recommended protrusion: 0.6 mm to 0.7 mm)
- 3) To adjust the height of the feed dog:
  - (1) Loosen screw ② of crank ① .
  - (2) Move the feed bar up or down to make adjustment.
  - (3) Securely tighten screw ② .

**\* Precaution**

**If the screw is tighten too securely, the crank will be abraded.**

a . Feed dog    b. Throat plate

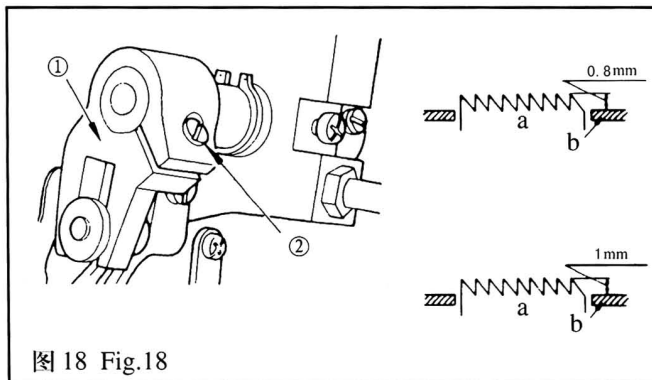



## 14. 针与旋梭的关系( 图 20)

### 14. NEEDLE-TO-HOOK RELATIONSHIP (Fig.20)

1. 针与旋梭的关系应配合如下:

1) 转动上轮, 使针杆位于最低点, 再旋松针杆连接柱定位螺钉。

\* 针杆高度的确定

2) 拉动针杆, 水平透过内梭内边缘可看到针孔有 1/2 下露 (机针必须安装到位)。机针埋线槽朝左, 然后旋紧针杆连接柱螺钉。

\* 旋梭位置的确定

3) 先将旋梭梭尖朝上, 转动皮带轮针杆从最低点回升时, 观察旋梭与机针配合关系。当旋梭梭尖位于机针孔边上端 1-1.5mm 时且梭尖平面距机针短槽平面 0.05mm 时 (保证梭尖位于机针的中心线部位), 旋紧旋梭螺钉。

\* 注意

若间隙太小, 会磨损梭尖, 若间隙太大, 则会引起跳针。

\* 旋梭原来用什么型号, 调换后, 也请使用原来的型号;

更换机针后注意机针必须安装到位且类型相同。如不同类型机针须检查配合关系。

#### **1. Adjust the timing between the needle and the hook as follows:**

1) Turn the handwheel to bring the needle bar down to the lowest point of its stroke, and loosen setscrew.

\* Adjusting the needle bar height

2) Pull the needle bar, you can see the Pinhole basset 1/2 level through edge of inside hook (needle must be position) . Turn needle cover wire slot left, then tighten setscrew.

\* Adjusting position a of the hook

3) First move the point of hook in the direction, when running strap pulley needle bar risen from the lowest, Observe cooperate relation of the hook and needle. When hook point above Pinhole about top of 1mm to 1.5mm and when plane of the hook point from plane of needle short bar 0.05mm (keep the align hook blade point with the center of needle), tighten the hook setscrews.

\* **Precaution**

**If the clearance is too small, the tip of the hook will be abraded. If it is too big, it will lead to skip over.**

\* **Note that the type of hook to be substituted for, when replacing the hook, shall be in conformity with the very type of the hook installed in the sewing machine of original assemblage.**

After replacing the needle, the needle must be same type and install right position. If the needle is different type need check Match with relation.



图20

### 15. 压杆高度的调节( 图 21)

### 15. ADJUSTING THE HEIGHT OF THE PRESSER BAR (Fig.21)

1) 旋松压杆导架紧固螺钉①，调节压杆高度与压脚角度。

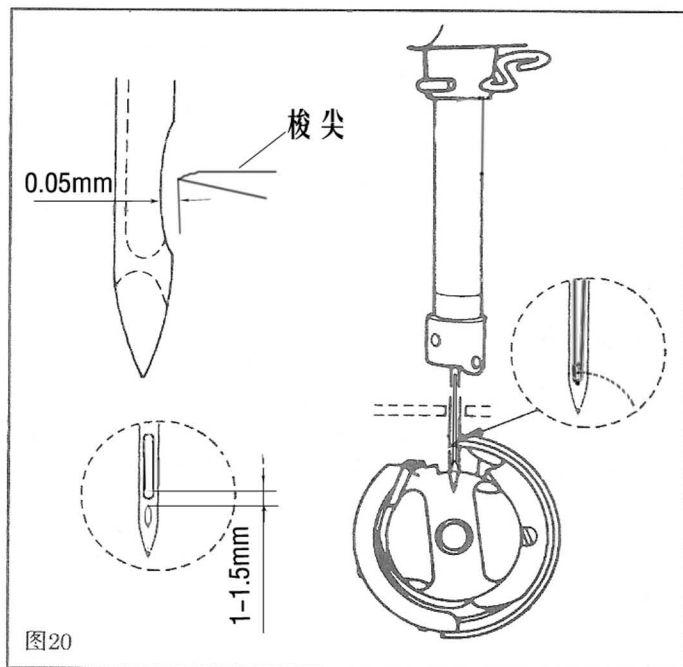
2) 调整后，拧紧紧固螺钉。

1) Loosen setscrew ①, and adjust the presser bar height and the angle of the presser foot.

2) After adjustment, securely tighten the setscrew.



图21 Fig. 21

## 16. 挑线挑线量的调节(图 22)

### 16. ADJUSTING THE THREAD TAKE-UP STROKE (Fig.22)

1 缝制厚料时, 应将右线钩①朝左方向 A 移动, 以增大挑线量。

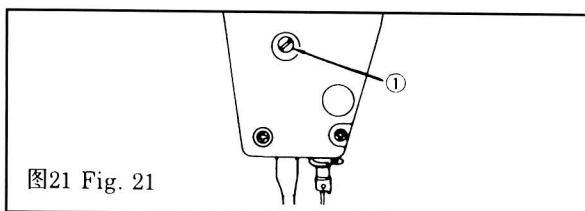
2 缝制薄料时, 应将右线钩①朝右方向 B 移动, 以减小挑线量。

3) 右线钩①中心与螺钉中心一致时为标准位置。

1) When sewing heavy-weight materials, move thread guide ① to the left in direction A to increase the length of thread pulled out by the thread take-up.

2) When sewing light-weight materials, move thread guide ① to the right in direction B to decrease the length of thread pulled out by the thread take-up.

3) When the center of the thread guide ① is aligned with the center of the screw, it is standard.

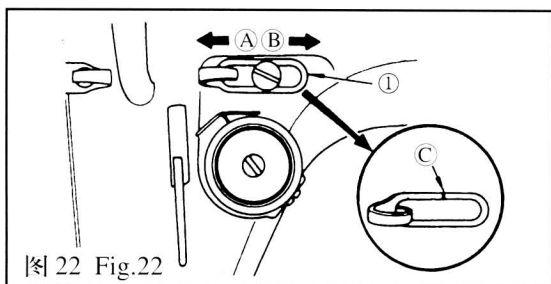

## 17. 皮带罩绕线器的装法(图 23、图 24、图 25)

### 17. INSTALLING THE BELT COVER AND THE BOBBIN WINDER (Fig.23, Fig.24, Fig.25)

1. 安装程序:

1) 在台板上钻四只木螺钉导孔 A、B、C、D。

2) 将罩壳支柱①装入机壳的螺孔内。

3) 将上轮前罩壳③从后斜方装入, 使上轮套进上轮前罩壳③的孔内。

4) 将上轮后罩壳②放置在导孔 C D 上。

5) 用螺钉和垫圈④⑤⑥, 将上轮前罩壳固定在车壳上, 此时的螺钉紧固扭矩请控制在螺钉④为 30kg·cm、螺钉⑤为 25kg·cm, 即使紧固扭矩超过以上程度, 也无效果。

6) 盖上上轮前罩盖板⑦。

7) 将上轮后罩壳②向后方移动, 在上轮后罩壳②的橡胶部分碰到上轮前罩壳③时, 再移动 0.5-1mm, 将其用木螺钉和垫圈固定。

8) 用木螺钉将绕线器⑧固定在导孔 A 和 B 上。

## 1.Installing procedure

- 1) Drill four wooden screw guide holes A, B, C and D in the machine table.
- 2) Insert support ① in the tapped hole in the arm .
- 3) Install the front belt cover ③, get the hand wheel in the middle of the hole.
- 4) Install the back belt cover ② at C and D.
- 5) Using the screws ④ , ⑤ and washer ⑥ fix the front belt cover ③ on the support the tightening torque for the screw ④ is about 30 kg·cm, for the screw ⑤ is about 25 kg·cm.
- 6) Fix the cover ⑦ .
- 7) Move the back belt cover ② backward until its rubber touches the front belt cover ③ , then move further more 0.5-1 mm, fix it using the wooden screws and washers.
- 8) Fix bobbin winder ⑧ at A and B using the wooden screws.

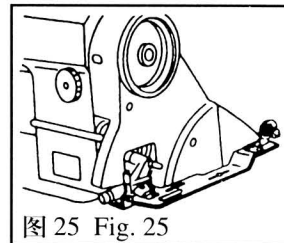
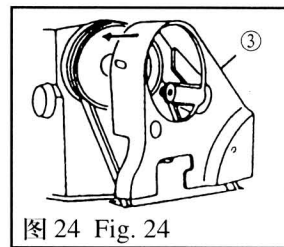
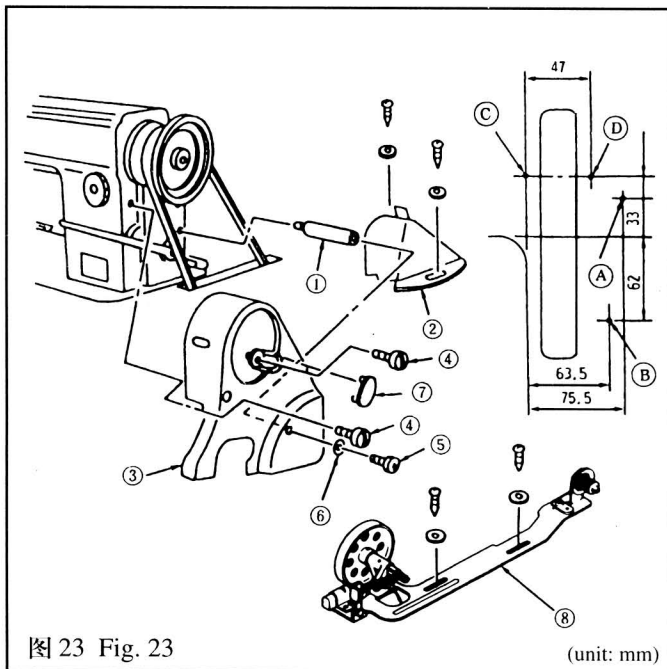

## 18. 膝提高度的调节(图 26、27 图)

## 18. ADJUSTING THE HEIGHT OF THE KNEE LIFTER (Fig.26, Fig.27)

- 1) 用膝提时的标准压脚高度是 10 毫米。
- 2) 用膝提调整螺钉①可以调节压脚提升量至 13 毫米。
- 3) 当压脚提升量超过 10 毫米时,不能使处于最低位置的针杆②的底端与压脚③相碰。
- 1) The standard height of the presser foot lifted using the knee lifter is 10 mm.
- 2) You can adjust the presser foot lift up to 13 mm using knee lifter adjust screw ① .
- 3) When you have adjusted the presser foot lift to over 10 mm, be sure that bottom end of needle bar ② in its lowest position does not hit presser foot ③ .

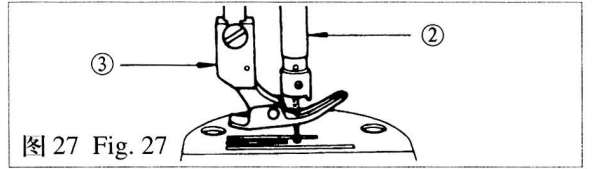
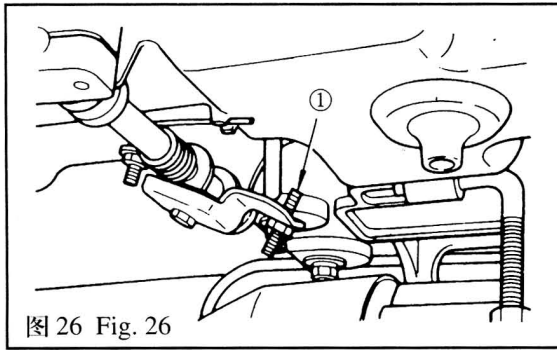

**19. 规格**  
**19. SPECIFICSTIONS**

	Model	Model
缝料	中厚料用	厚料用
缝速	最大每分钟 5000 针	最大每分钟 3500 针
线迹长度	5mm (最大)	5mm (最大)
压脚提升高度 (膝提)	10mm (标准) 13mm (最大)	10mm (标准) 13mm (最大)
机针	DB × 1 #9~#18	DB × 1 #20~#23
润滑油	10 号白油	

	Model	Model
Application	For medium-weight materials	For heavy-weight materials
Sewing speed	Max. 5,000 s.p.m.	Max. 3,500 s.p.m.
Stitch length	Max. 5mm	Max. 5mm
Presser foot lift (by knee lifter)	10mm(standara) 13mm(max.)	1mm(standard) 13mm(max.)
Needle	DB × 1 #9~#18	DB × 1 #20~#23
Lubricating oil	10 white oil	

## 20. 一般故障及其处理方法

故障类型	产生原因	处理方法
断 针	<ol style="list-style-type: none"> <li>1. 机针太细或机针弯曲</li> <li>2. 机针装法错误</li> <li>3. 缝纫时用手推拉缝料</li> <li>4. 缝料过于坚厚</li> </ol>	调换机针 参看第 8 页图 10 稍许加以扶持，不可推拉 请按技术规格规定使用
跳 针	<ol style="list-style-type: none"> <li>1. 机针弯曲或机针粗细和 缝料厚薄不相称</li> <li>2. 机针装法错误</li> </ol>	调换机针 参看第 8 页图 10
断面线	<ol style="list-style-type: none"> <li>1. 穿线错误</li> <li>2. 面线太紧</li> <li>3. 线的质量差</li> <li>4. 机针太细, 机针粗糙</li> </ol>	参看第 9 页图 12 参看第 10 页图 14 来调节面线张力 调换缝线 调换机针
断底线	<ol style="list-style-type: none"> <li>1. 底线太紧</li> <li>2. 梭心绕线松乱, 不匀</li> <li>3. 针板孔毛糙或磨损</li> </ol>	减小底线张力 重新绕线 更换针板或用 0 <sup>#</sup> 砂布抛光
针迹松浮	<ol style="list-style-type: none"> <li>1. 底面线松紧没调好</li> <li>2. 挑线簧过松</li> </ol>	重新调整底面线 参看第 11 页图 15, 调节挑线簧张力
缝纫起皱	<ol style="list-style-type: none"> <li>1. 缝料过薄而针距太长</li> <li>2. 底、面线张力过紧</li> <li>3. 压脚压力过强</li> <li>4. 送料牙过分凸出</li> </ol>	适当调整 调节夹线螺母、挑线簧和梭皮螺钉 旋松调压螺钉，减轻压脚的压力 参看第 14 页图 18, 调节送料牙高度

<b>Malfunction type</b>	<b>Reasons</b>	<b>Disposal</b>
<b>Break needle</b>	<ol style="list-style-type: none"> <li>1. The needle is too thin or flexure</li> <li>2. The needle' s installation is wrong</li> <li>3. Push or pull to sew by hand</li> <li>4. Material is too heavy</li> </ol>	<ol style="list-style-type: none"> <li>1. Transpose needle</li> <li>2. Look into page 8 figure 10</li> <li>3. Take in to support a little, can't push or pull</li> <li>4. Please observe technique state</li> </ol>
<b>Jump needle</b>	<ol style="list-style-type: none"> <li>1. The needle is flexure or the needle' s thickness is disproportional with material thickness</li> <li>2. The needle' installation is wrong</li> </ol>	<ol style="list-style-type: none"> <li>1. Transpose needle</li> <li>2. Look into page 8 figure 10</li> </ol>
<b>Section thread</b>	<ol style="list-style-type: none"> <li>1. Thread is wrong</li> <li>2. Thread is too tight</li> <li>3. The thread' s quantity is too bad</li> <li>4. the needle is too thin and coarseness</li> </ol>	<ol style="list-style-type: none"> <li>1. Look into page 9 figure 12</li> <li>2. Look into page 10 figure 14 to adjust tight</li> <li>3. Transpose suture</li> <li>4. Transpose needle</li> </ol>
<b>Break bottom thread</b>	<ol style="list-style-type: none"> <li>1. Bottom thread is too tight</li> <li>2. The core of bobbin rounds thread loose disorderly, not uniformity</li> <li>3. Throat plate bore coarseness or abrasion</li> </ol>	<ol style="list-style-type: none"> <li>1. Minish bottom thread tight</li> <li>2. Re- round thread</li> <li>3. Replacing the throat plate or polished by emery cloth</li> </ol>
<b>vestige of needle float</b>	<ol style="list-style-type: none"> <li>1. The bottom noodles thread is loose and tune up tightly</li> <li>2. Thread take-up spring is too loosen</li> </ol>	<ol style="list-style-type: none"> <li>1. Re-adjust bottom noodles thread</li> <li>2. Look into page 11 figure 15 to adjust thread take-up spring tight</li> </ol>
<b>Sewing shrivel</b>	<ol style="list-style-type: none"> <li>1. Materials is too thin and the needle is too long</li> <li>2. The bottom noodles tension too tightly</li> <li>3. Lifter pressure too strong</li> <li>4. Free dog bulge excessively</li> </ol>	<ol style="list-style-type: none"> <li>1. Appropriate adjustment</li> <li>2. Adjust tension nut, take-up spring and screw</li> <li>3. unscrew presser spring regulator, ease off Lifter pressure</li> <li>4. Look into page 14 figure 18, adjust the height of free dog</li> </ol>

零件样本  
Parts Book



1. 机壳分组件 Arm bed components

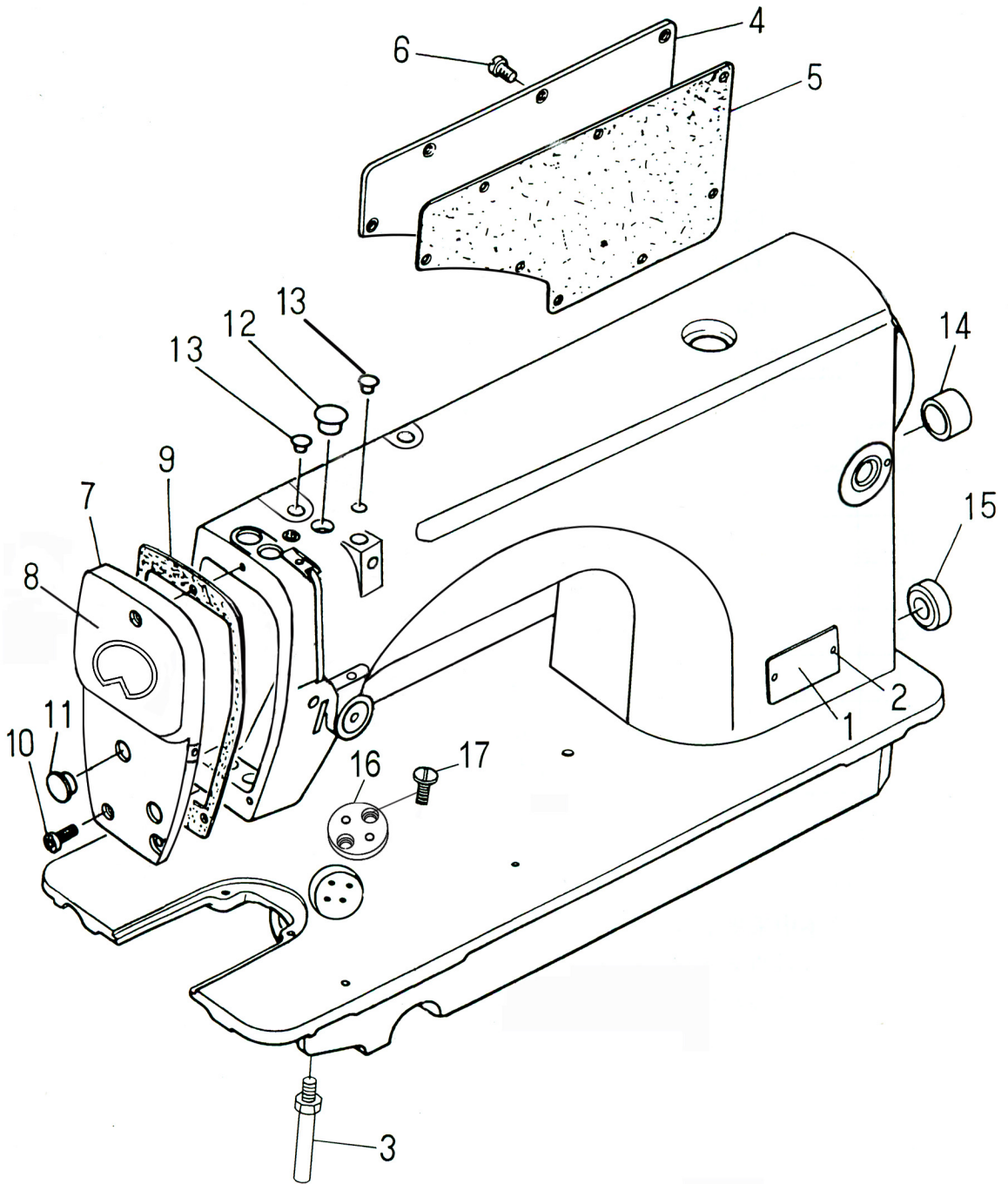

## 中厚料用

## For medium heavy materials

### 1. 机壳部件

### 1. Arm bed components

序号 Ref.No.	件号 Part No.	名称	Description	数量 Amt.
1	10137001	型号牌	Model plate	1
2	R03001	型号牌铆钉	Model plate rivet	2
3	101S12001	底板支柱	Bed screw stud	4
4	10312001	后窗板	Side plate	1
5	10322001	后窗板垫	Gasket	1
6	101S11001	螺钉 SM3/16"×28 L=9	ScrewSM3/16"×28 L=9	8
7	10301002	面板	Face plate arm	1
8	10137002	商标牌	Plate with trademark	1
9	10222001	面板垫	Gasket	1
10	101S11001	螺钉 SM3/16"×28 L=9	ScrewSM3/16"×28 L=9	3
11	10122003	面板调节螺孔塞	Rubber plug	2
12	10122004	针杆曲柄螺孔塞	Rubber plug	1
13	10122005	挑线连杆销螺孔塞	Rubber plug	2
14	10122006	送料调节器孔塞	Rubber plug	1
15	10122007	下轴盲孔塞	Rubber plug	1
16	10112002	卷边器座	Coil side pedestal	1
17	101S11002	螺钉 SM11/64"×40 L=5.5	ScrewSM11/64"×40 L=5.5	2

## 2. 上轴、挑线分组件 Main shaft, take-up components

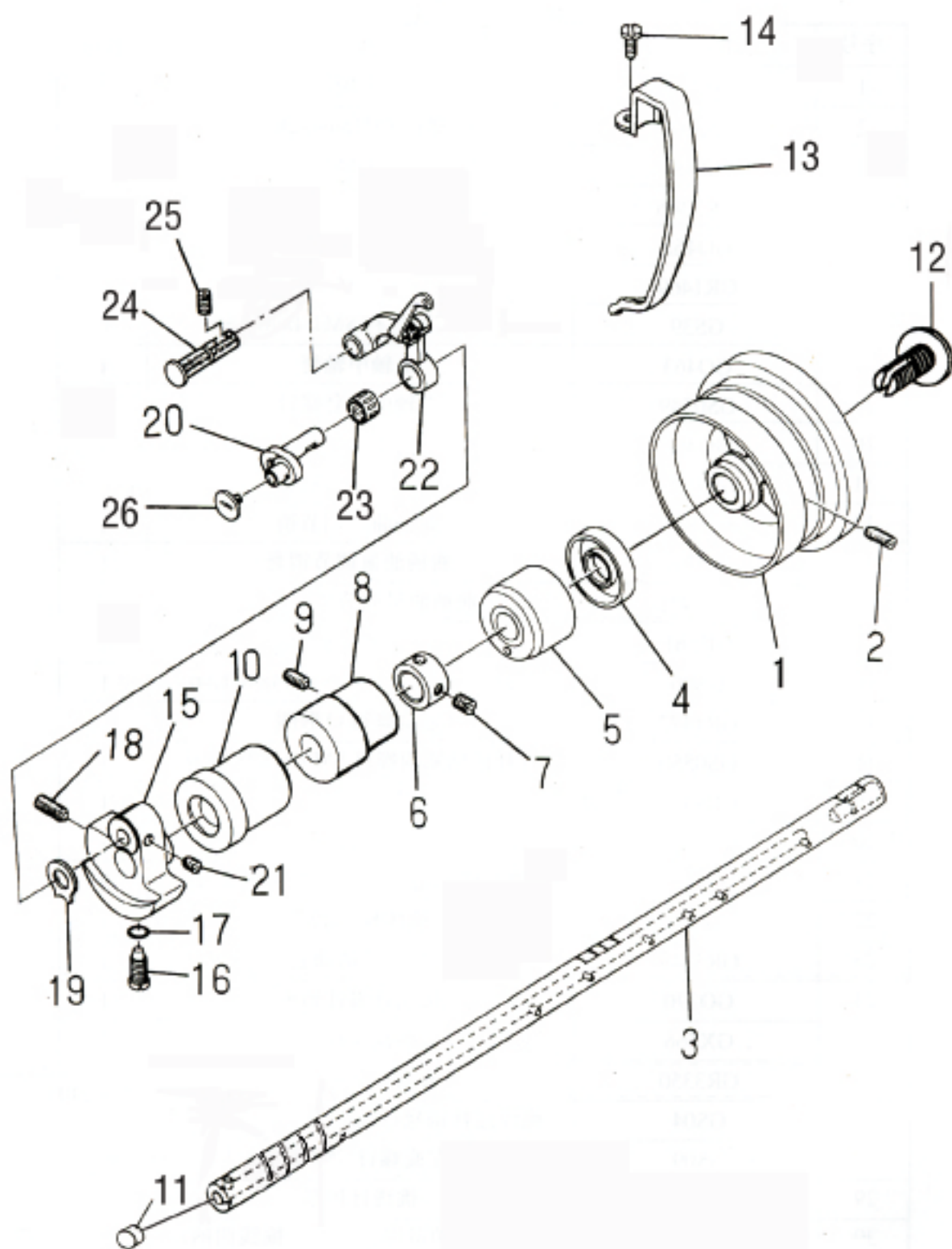

## 2. 上轴、挑线分组件

## 2. Main shaft、take-up components

序号 Ref. No.	件号 Part No.	名称	Description	数量 Amt.
1	10135001	上轮	Hand wheel	1
2	101S15001	螺钉 SM15/64"×28 L=15	ScrewSM15/64"×28 L=15	2
3	10102001	上轴	Main shaft	1
4	10422003	上轴油封(8800用)	Main shaft	1
	10122008	上轴油封(美衣达用)	Main shaft	1
5	10103001	上轴后轴套	Main shaft bushing, rear	1
6	10408001	上轴挡圈(8800用)	Thrust collar asm.	1
	10108001	上轴挡圈(美衣达用)	Thrust collar asm.	1
7	101S15007	螺钉 SM1/4"×40 L=6	ScrewSM1/4"×40 L=6	2
8	10403002	上轴中轴套(8800用)	Brshing, intermediate	1
	10103003	上轴中轴套(美衣达用)	Brshing, intermediate	1
9	101S15006	螺钉 SM15/64"×28 L=7	ScrewSM15/64"×28 L=7	1
10	1040300300	上轴前轴套(8800用)	Main shaft	1
	1010300400	上轴前轴套(美衣达用)	Main shaft	1
11	10122012	上轴孔塞	Rubber plug	1
12	101S30001	螺钉 SM5/16"×24 L=14	ScrewSM5/16"×24 L=14	1
13	10112004	挑线杆护罩	Thread takeup lever	1
14	101S11004	螺钉 SM3/16"×28 L=6	ScrewSM3/16"×28 L=6	1
15	10404001	针杆曲柄(8800用)	Counterweight	1
	10104001	针杆曲柄(美衣达用)	Counterweight	1
16	101S11003	螺钉 SM9/32"×28 L=16	ScrewSM9/32"×28 L=16	1
17	10122010	定位螺钉 O形圈	Rubber ring	1
18	101S15004	螺钉 SM9/32"×28 L=16	ScrewSM9/32"×28 L=16	1
19	10112003	针杆曲柄护板	Counterweight	1
20	10404006	挑线曲柄部件(8800用)	Needle bar crank asm.	1
	1011000100	挑线曲柄部件(美衣达用)	Needle bar crank asm.	1
21	101S15002	螺钉 SM1/4"×40 L=6	ScrewSM1/4"×40 L=6	2
22	1043800100	挑线杆分部件(8800用)	Thread takeup lever	1
	1013800100	挑线杆分部件(美衣达用)	Thread takeup lever	1
23	10124001	挑线杆滚针轴承	Needle bearing	1
24	10126001	挑线连杆销	Thread takeup crank	1
25	101S15001	螺钉 SM15/64"×28 L=15	ScrewSM15/64"×28 L=15	1
26	104S17001	螺钉 SM9/64"×40 L=6(8800用)	ScrewSM9/64"×40 L=6	1
	101S17001	螺钉 SM9/64"×40 L=6(美衣达用)	ScrewSM9/64"×40 L=6	1

### 3. 针杆、夹线分组件 Needle bar、thread tension components

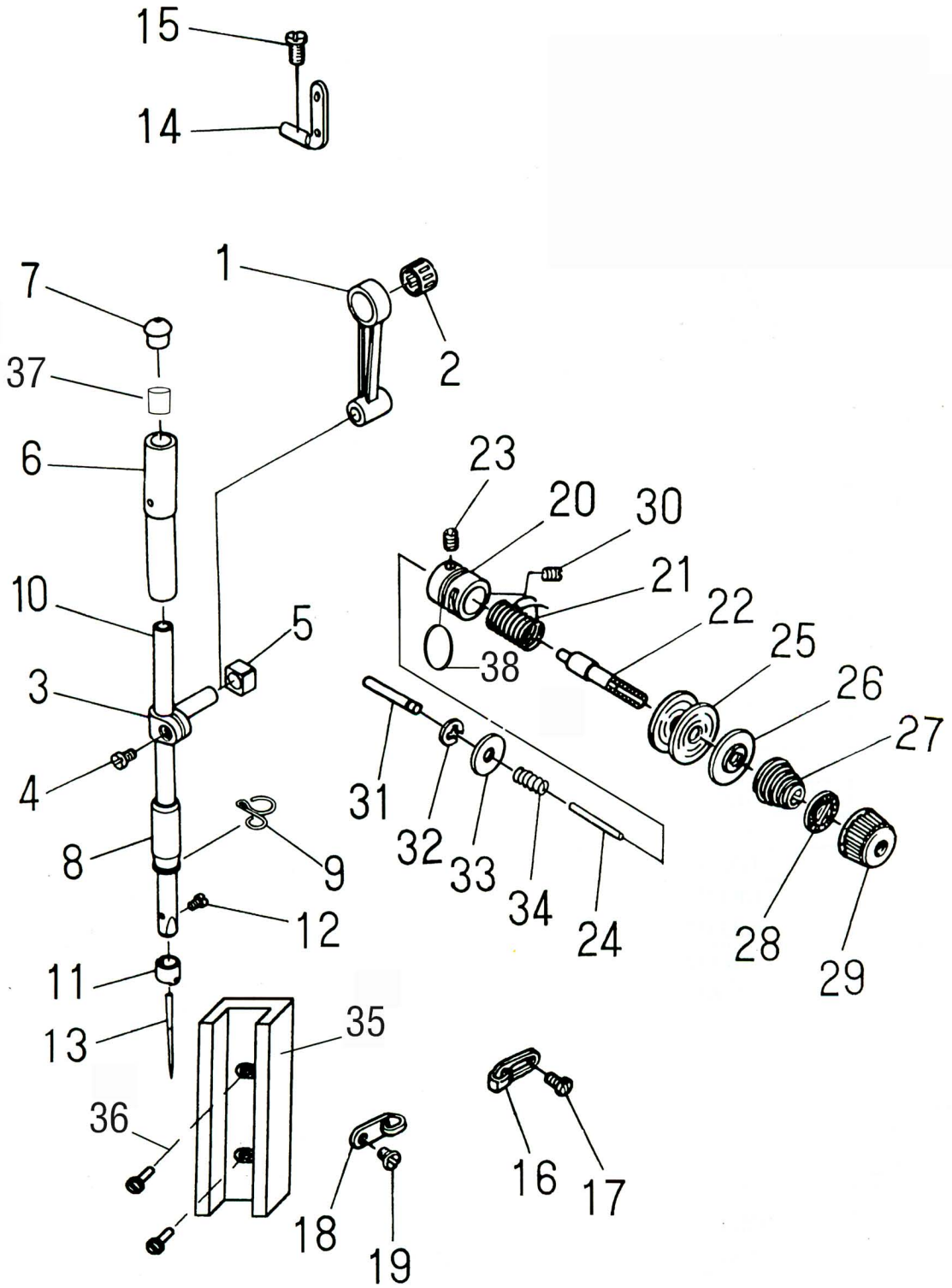

## 3. 针杆、夹线分组

## 3. Needle bar、thread tension components

序号 Ref. No.	件号 Part No.	名称	Description	数量 Amt.
1	10405002	针杆连杆(8800用)	Needle bar crank rod	1
	10105002	针杆连杆(美衣达用)	Needle bar crank rod	1
2	10124001	针杆连杆滚针轴承	Needle bearing	1
3	10438002	针杆连接柱(8800用)	Needle bar connection asm.	1
	10138002	针杆连接柱(美衣达用)	Needle bar connection asm.	1
4	101S11005	螺钉 SM9/64"×40 L=6	Screw	1
5	10109001	针杆连接柱滑块	Slide block	1
6	10103009	针杆上衬套	Needle bar bushing,upper	1
7	10122013	针杆上衬套孔塞	Cap	1
8	10403008	针杆下衬套(8800用)	Needle bar bushing,lower	1
	10103010	针杆下衬套(美衣达用)	Needle bar bushing,lower	1
9	10413001	针杆下衬套线勾(8800用)	Needle bar thread guide	1
	10113001	针杆下衬套线勾(美衣达用)	Needle bar thread guide	1
10	10102002	针杆	Needle bar	1
11	10113002	针杆线勾	Needle bar thread guide	1
12	101S11006	螺钉 SM1/8"×44 L=4.5	ScrewSM1/8"×44 L=4.5	1
13	10117001	机针	Needle	1
14	10113003	二眼线勾	Two hole thread eyelet	1
15	101S11004	螺钉 SM3/16"×28 L=6	ScrewSM3/16"×28 L=6	1
16	10113004	右线勾	Frsme thred guide,right	1
17	101S11007	螺钉 SM11/64"×40 L=6	ScrewSM11/64"×40 L=6	1
18	10113005	左线勾	Frsme thred guide,left	1
19	101S11007	螺钉 SM11/64"×40 L=6	ScrewSM11/64"×40 L=6	1
20	10403009	挑线簧调节座	Tension post socket	1
21	10127001	挑线簧	Takeup spring	1
22	101S30002	夹线螺钉 SM1/4"×40 L=17.5	ScrewSM1/4"×40 L=17.5	1
23	101S15005	螺钉 SM9/64"×40 L=5.5	ScrewSM9/64"×40 L=5.5	1
24	10126002	松线钉	Thread release pin	1
25	10112005	夹线板	Tension disc	2
26	10112006	松线板	Tension disc holder	1
27	10127002	夹线簧	Tension spring	1
28	10112007	夹线制动板	Tension disc stopper	1
29	104S16001	夹线螺母 SM1/4"×40 L=10(8800用)	Tension nutSM1/4"×40	1
	101S16007	夹线螺母 SM1/4"×40 L=10(美衣达用)	Tension nutSM1/4"×40	1
30	101S15010	螺钉 SM15/64"×28 L=10.5	ScrewSM15/64"×28 L=10.5	1
31	10126003	松线辅钉	Tension release	1
32	H05003	松线辅钉挡圈	Snap ring	1
33	10128001	垫片	Washer plate	1
34	10127003	松线辅钉弹簧	Tension release pin spring	1
35	10109002	针杆滑块槽	Needle bar trough	1
36	101S11008	螺钉 SM11/64"×40 L=8	ScrewSM11/64"×40 L=8	2
37	10123002	针杆上毡塞	Oil felt for needle bar	1
38	10122014	O形圈	Rubber ring	1

#### 4. 压料分组件 Presser bar components

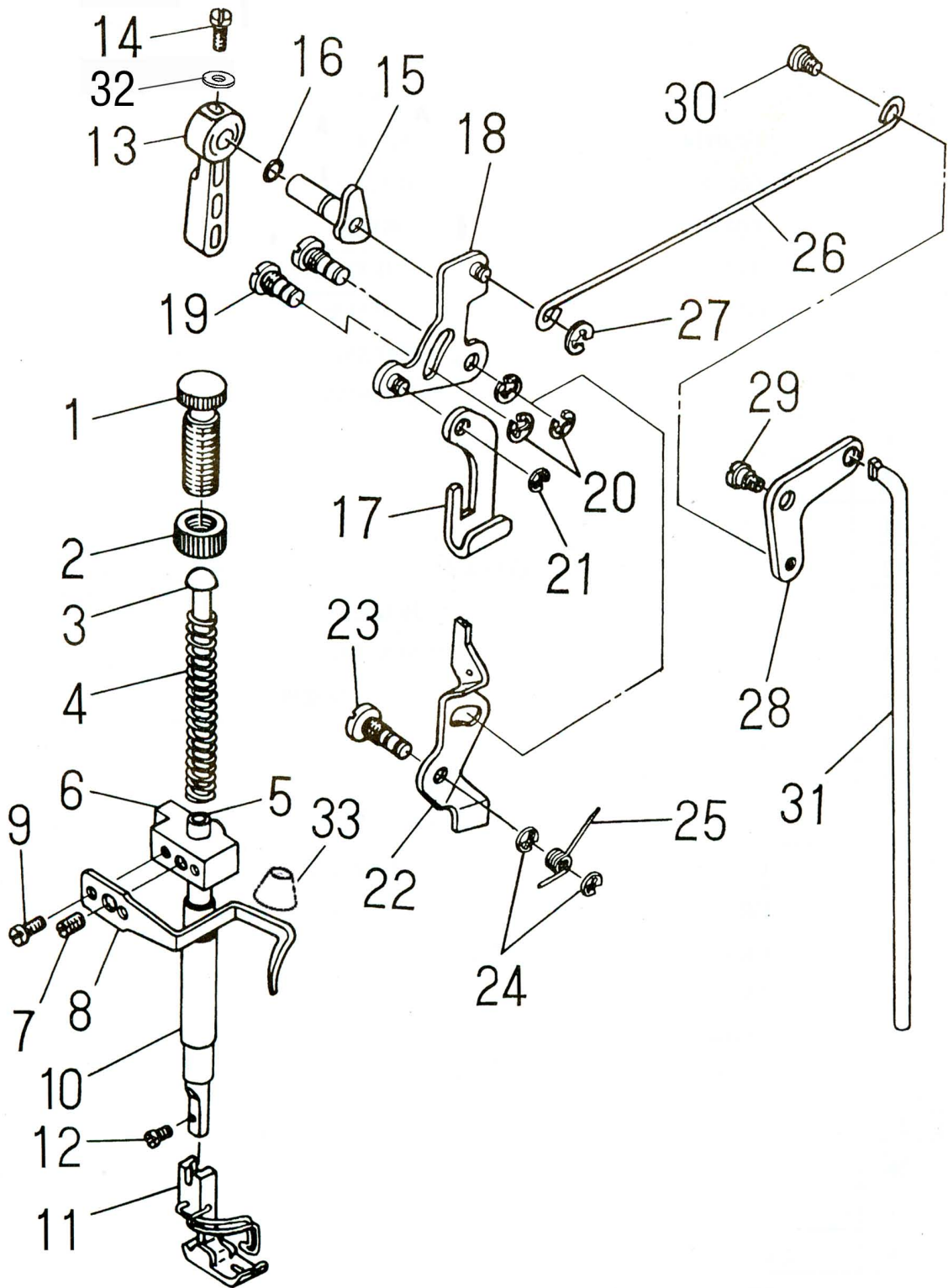

## 4. 压料分组件

## 4. Presser bar components

序号 Ref. No.	件号 Part No.	名称	Description	数量 Amt.
1	101S30004	调压螺钉 SM1/2"×28 L=47(8800 用)	Presser spring regulatorSM1/2"×28	1
	101S16008	调压螺钉 SM1/2"×28 L=47(美衣达用)	Presser spring regulatorSM1/2"×28	1
2	101S16002	调压螺母 SM1/2"×28 L=8(8800 用)	NutSM1/2"×28 L=8	1
	101S30020	调压螺母 SM1/2"×28 L=8(美衣达用)	NutSM1/2"×28 L=8	1
3	10102003	调压导杆	Presser guide bar	1
4	10127005	调压簧	Presser spring	1
5	10102004	压杆	Presser bar	1
6	10409001	压杆导架(8800 用)	Needle bar guide bracket	1
	10109003	压杆导架(美衣达用)	Needle bar guide bracket	1
7	101S15007	螺钉 SM1/4"×40 L=8	ScrewSM1/4"×40 L=8	1
8	10413003	缓线调节钩(8800 用)	Presser bar thread guide	1
	10113008	缓线调节钩(美衣达用)	Presser bar thread guide	1
9	101S11005	螺钉 SM9/64"×40 L=6	ScrewSM9/64"×40 L=6	2
10	10103012	压杆衬套	Presser bar bushing lower	1
11	1011600100	活压脚部件	presser foot asm.	1
12	101S11009	螺钉 SM9/64"×40 L=10.5	ScrewSM9/64"×40 L=10.5	1
13	10111001	压脚扳手(8800 用)	Hand lifter	1
	10111018	压脚扳手(美衣达用)	Hand lifter	1
14	101S11010	螺钉 SM9/64"×40 L=11	ScrewSM9/64"×40 L=11	1
15	1041000200	压脚扳手凸轮分部件(8800 用)	Hand lifter cam asm.	1
	1011000200	压脚扳手凸轮分部件(美衣达用)	Hand lifter cam asm.	1
16	O01004	O 形圈	Rubber ring	1
17	10412002	压脚升降板(8800 用)	Lifting lever	1
	10112010	压脚升降板(美衣达用)	Lifting lever	1
18	10412003	抬压脚前杠杆分部件(8800 用)	Hand lifter link asm.	1
	1011201100	抬压脚前杠杆分部件(美衣达用)	Hand lifter link asm.	1
19	101S20001	前杠杆螺纹销 SM5/16"×24 L=5.5	Link shaftSM5/16"×24 L=5.5	2
20	H05009	螺纹销开口挡圈	Snap ring	3
21	H05009	升降板连接特制开口挡圈	Lifting lever ring	1
22	10112012	松线顶板	Tension release plate	1
23	101S20002	松线顶板螺纹销 SM5/16"×24 L=6.5	Tension release shaftSM5/16"×24	1
24	H05009	螺纹销开口挡圈	Snap ring	2
25	10127008	松线顶板复位簧	Tension release return spring	1
26	10412004	抬压脚拉杆(8800 用)	Lifting lever connecting rod	1
	10112013	抬压脚拉杆(美衣达用)	Lifting lever connecting rod	1
27	H05009	拉杆开口挡圈	Snap ring	1
28	10412005	抬压脚后杠杆(8800 用)	Lifting lever link	1
	10112014	抬压脚后杠杆(美衣达用)	Lifting lever link	1
29	101S20003	后杠杆轴位螺钉 SM15/64"×28 L=6.4	Hinge screwSM15/64"×28 L=6.4	1
30	101S20004	抬牙脚拉杆螺钉 SM3/16"×32 L=5	Hinge screwSM3/16"×32 L=5	1
31	10412006	抬压脚顶杆(8800 用)	Connecting rod vertical	1
	10112015	抬压脚顶杆(美衣达用)	Connecting rod vertical	1
32	10128002	垫圈	Washer	1
33	10122034	压杆防油套	Presser bar defend oil bushing	1



## 5. 勾线分组件 Hook driving shaft compinents

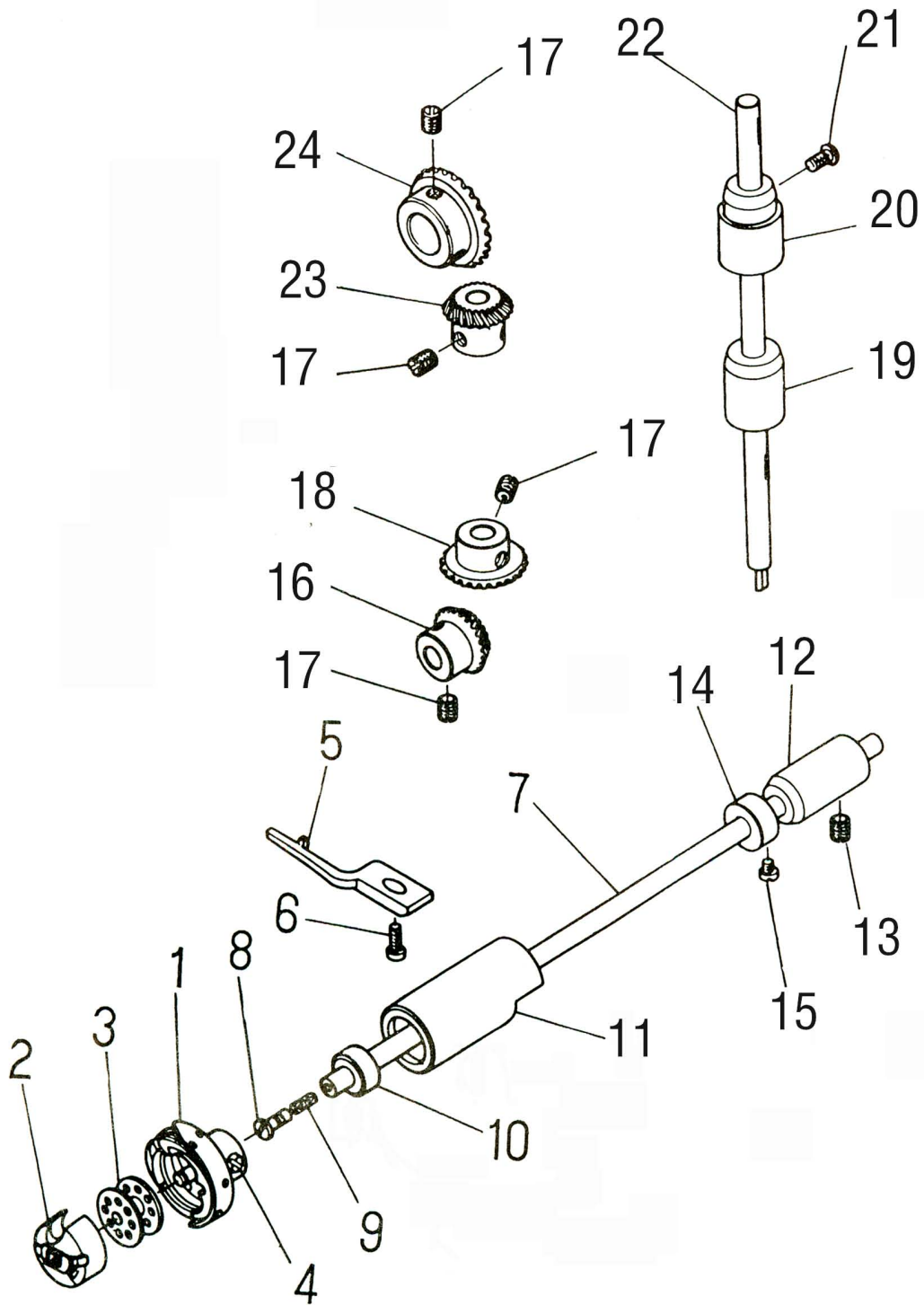

## 5. 钩线分组件

## 5. Hook driving shaft components

序号 Ref. No.	件号 Part No.	名称	Description	数量 Amt.
1	10118504	旋梭 (广濑)	Hook asm	1
	10118001	旋梭 (JACK)	Hook asm	1
2	10118501	梭壳 (广濑)	Bobbin case asm	1
	10118002	梭壳 (国产)	Bobbin case asm	1
3	10118003	梭心	Bobbin	1
4	101S15008	旋梭紧固螺钉 SM11/64"×40 L=4	ScrewSM11/64"×40 L=4	1
5	10412008	旋梭定位钩(8800用)	Positioning finger	1
	10112016	旋梭定位钩(美衣达用)	Positioning finger	1
6	101S11011	螺钉 SM11/64"×40 L=9.5	ScrewSM11/64"×40 L=9.5	1
7	10102006	下轴	Hook driving shaft	1
8	101S30005	螺钉 SM3/16"×32 L=13	ScrewSM3/16"×32 L=13	1
9	10123003	下轴限油芯	Oil wick	1
10	10122015	下轴油封	Thrust collar	1
11	1040301000	下轴前轴套分部件(8800用)	Bushing asm. front	1
	1010301300	下轴前轴套分部件(美衣达用)	Bushing asm. front	1
12	10403012	下轴后轴套(8800用)	Bushing, rear	1
	10103015	下轴后轴套(美衣达用)	Bushing, rear	1
13	101S15006	螺钉 SM15/64"×28 L=7	ScrewSM15/64"×28 L=7	1
14	10408002	下轴挡圈(8800用)	Thrust collar asm.	1
	10108002	下轴挡圈(美衣达用)	Thrust collar asm.	1
15	101S11012	螺钉 SM11/64"×40 L=4.8	ScrewSM11/64"×40 L=4.8	2
16	10425001	下轴伞齿轮(小)(8800用)	Pinion asm.	1
	10125001	下轴伞齿轮(小)(美衣达用)	Pinion asm.	1
17	101S15009	螺钉 SM1/4"×40 L=5.5	ScrewSM1/4"×40 L=5.5	4
18	10425002	竖轴下伞齿轮(大)(8800用)	Gear asm. large	1
	10125002	竖轴下伞齿轮(大)(美衣达用)	Gear asm. large	1
19	10403013	竖轴下轴套(8800用)	Upright shaft bushing, over	1
	10103016	竖轴下轴套(美衣达用)	Upright shaft bushing, over	1
20	10403014	竖轴上轴套(8800用)	Bushing, upper	1
	10103017	竖轴上轴套(美衣达用)	Bushing, upper	1
21	101S15006	螺钉 SM15/64"×28 L=7	ScrewSM15/64"×28 L=7	1
22	10102007	竖轴	Upright shaft	1
23	10425003	竖轴上伞齿轮(小)(8800用)	Pinion asm.	1
	10125003	竖轴上伞齿轮(小)(美衣达用)	Pinion asm.	1
24	10425004	上轴伞齿轮(大)(8800用)	Gear asm.	1
	10125004	上轴伞齿轮(大)(美衣达用)	Gear asm.	1

## 6. 送料分组件 Feed mechanism components

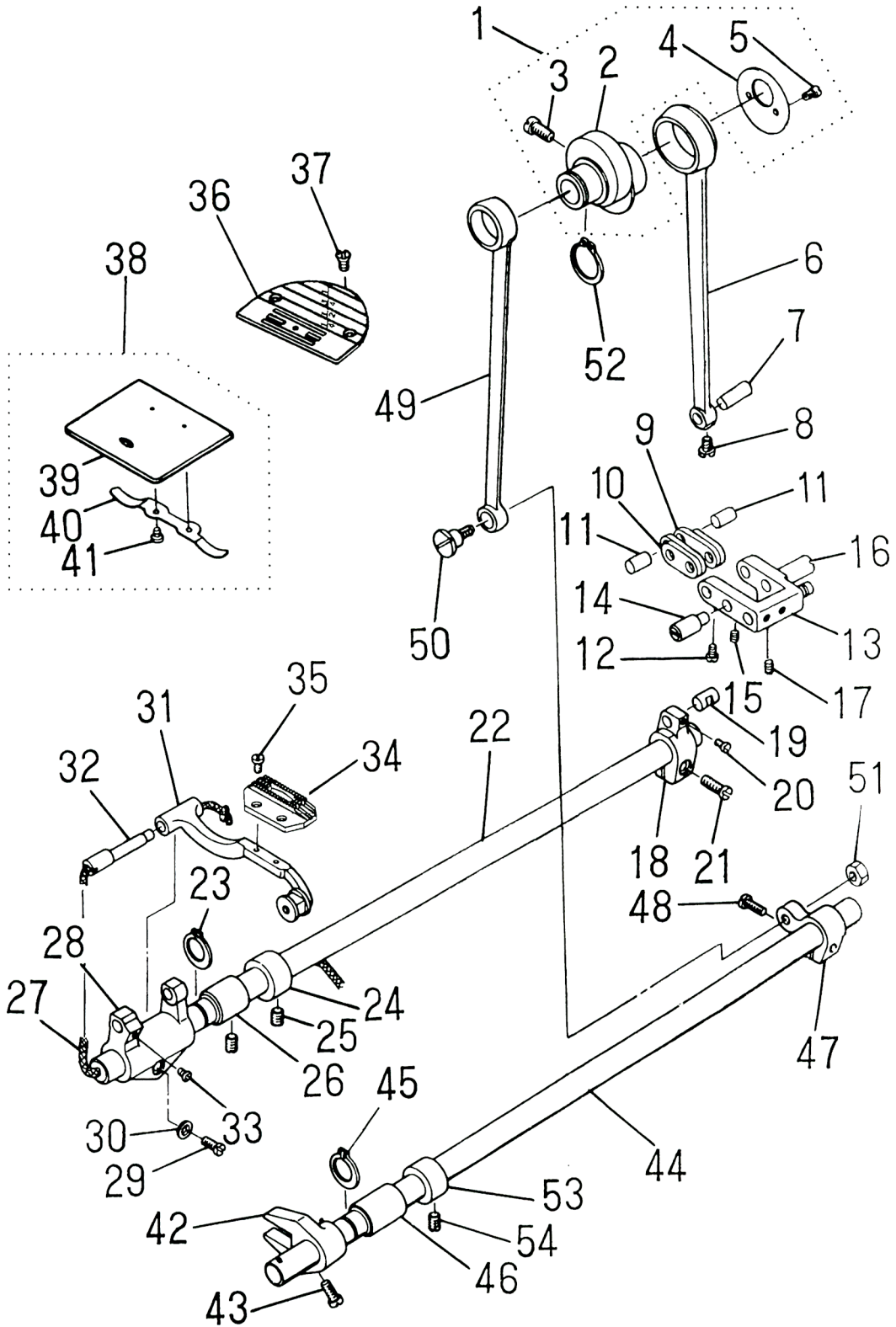

## 6. 送料分组件

## 6. Feed mechanism components

序号 Ref. No.	件号 Part No.	名称	Description	数量 Amt.
1	1011000300	送料偏心轮部件	Feed drive ecccntric cam asm.	1
2	10410001	送料偏心轮(8800用)	Feed drive ecccntric cam.	1
	10110003	送料偏心轮(美衣达用)	Feed drive ecccntric cam.	1
3	101S11013	螺钉 SM1/4"×40 L=13	ScrewSM1/4"×40 L=13	2
4	10112017	送料偏心轮盖板	Thrust collar	1
5	101S11005	螺钉 SM9/64"×40 L=5.5	ScrewSM9/64"×40 L=5.5	2
6	10405003	送料连杆(8800用)	Rocker shaft connecting rod	1
	10105003	送料连杆(美衣达用)	Rocker shaft connecting rod	1
7	10126006	送料连杆销	Walking foot pin	1
8	101S11005	螺钉 SM9/64"×40 L=6	ScrewSM9/64"×40 L=6	1
9	10109004	送料长摆动板	Walking foot link	2
10	10109005	送料短摆动板	Connecting link	2
11	10126007	短摆动板连杆销	Walking foot pin	2
12	101S11005	螺钉 SM9/64"×40 L=6	ScrewSM9/64"×40 L=6	2
13	1040400200	送料摆动板座部件(8800用)	Walking foot adjusting link	1
	1010100200	送料摆动板座部件(美衣达用)	Walking foot adjusting link	1
14	10126009	送料摆动板座左销	Adjusting link fulcrum shaft	1
15	101S15010	螺钉 SM15/64"×28 L=10.5	ScrewSM15/64"×28 L=10.5	1
16	10126010	送料摆动板座右销	Adjusting link fulcrum shaft	1
17	101S15010	螺钉 SM15/64"×28 L=10.5	ScrewSM15/64"×28 L=10.5	1
18	10404003	送料曲柄(8800用)	Feed rocker shaft crank asm	1
	10104002	送料曲柄(美衣达用)	Feed rocker shaft crank asm	1
19	10126011	送料曲柄销	Walking foot pin	1
20	101S11005	螺钉 SM9/64"×40 L=6	ScrewSM9/64"×40 L=6	1
21	101S11016	螺钉 SM3/16"×28 L=14	ScrewSM3/16"×28 L=14	1
22	10102008	送料轴	Feed rocker shaft	1
23	H03001	送料轴轴用挡圈	Retaining ring	1
24	10408001	送料轴挡圈(8800用)	Thrust collar asm.	1
	10108003	送料轴挡圈(美衣达用)	Thrust collar asm.	1
25	101S15002	螺钉 SM1/4"×40 L=6	ScrewSM1/4"×40 L=6	2
26	10103018	送料轴前轴套	Fccd tocker shaft bushing	1
27	10423004	送料轴油线	Oil wick	2
28	10401002	牙架座(8800用)	Feed rockcr asm.	1
	10101003	牙架座(美衣达用)	Feed rockcr asm.	1
29	101S11016	牙架座螺钉 SM3/16"×28 L=14	ScrewSM3/16"×28 L=14	1
30	10128003	牙架座螺钉垫圈	Washer	1
31	1040700100	牙架分部件(8800用)	Feed bar asm.	1
	1010700100	牙架分部件(美衣达用)	Feed bar asm.	1
32	10426005	牙架销(8800用)	Feed bar shaft	1
	10126013	牙架销(美衣达用)	Feed bar shaft	1
33	101S11025	螺钉 SM11/64"×40 L=7	ScrewSM11/64"×40 L=7	1
34	10114001	送料牙	Feed dog	1
35	101S11018	螺钉 SM1/8"×44 L=6	ScrewSM1/8"×44 L=6	2
36	10115001	针板	Throat plate	1
37	101S17002	螺钉 SM11/64"×40 L=6.4	ScrewSM11/64"×40 L=6.4	2
38	1011500200	推板分部件	Bed slide asm.	1
39	10115002	推板	Slide plate	1
40	10127009	推板簧	Bed slide spring	1
41	101S11019	螺钉 SM3/32"×56 L=1.9	ScrewSM3/32"×56 L=1.9	2
42	10404007	拾牙叉形曲柄(8800用)	Driving shaft crank asm.front	1
	10104003	拾牙叉形曲柄(美衣达用)	Driving shaft crank asm.front	1
43	101S11020	螺钉 SM11/64"×40 L=10.5	ScrewSM11/64"×40 L=10.5	1
44	10102009	拾牙轴	Feed driving shaft	1
45	10408001	拾牙轴轴用挡圈(8800用)	Retaining ring	1
46	10403015	拾牙轴前轴套(美衣达用)	Feed rocker shaft bushing	1
47	10404004	拾牙后曲柄(8800用)	Rear crank asm.	1
	10104004	拾牙后曲柄(美衣达用)	Rear crank asm.	1
48	101S11021	螺钉 SM3/16"×28 L=12	ScrewSM3/16"×28 L=12	1
49	10405003	拾牙连杆(8800用)	Connecting rod	1
	10105004	拾牙连杆(美衣达用)	Connecting rod	1
50	101S20005	拾牙连杆轴位螺钉 SM9/32"×28 L=13.5	Hinge screwSM9/32"×28 L=13.5	1
51	101S16003	螺母 SM19/32"×28 L=4	NutSM19/32"×28 L=4	1
52	H03002	拾牙连杆轴用挡圈	Snap ring	1
53	10408001	拾牙轴挡圈(8800用)	Thrust collar asm.	1
	10108003	拾牙轴挡圈	Thrust collar asm.	1
54	101S15002	螺钉 SM1/4"×40 L=6	ScrewSM1/4"×40 L=6	2

7. 送料调节分组件 Feed regulating components

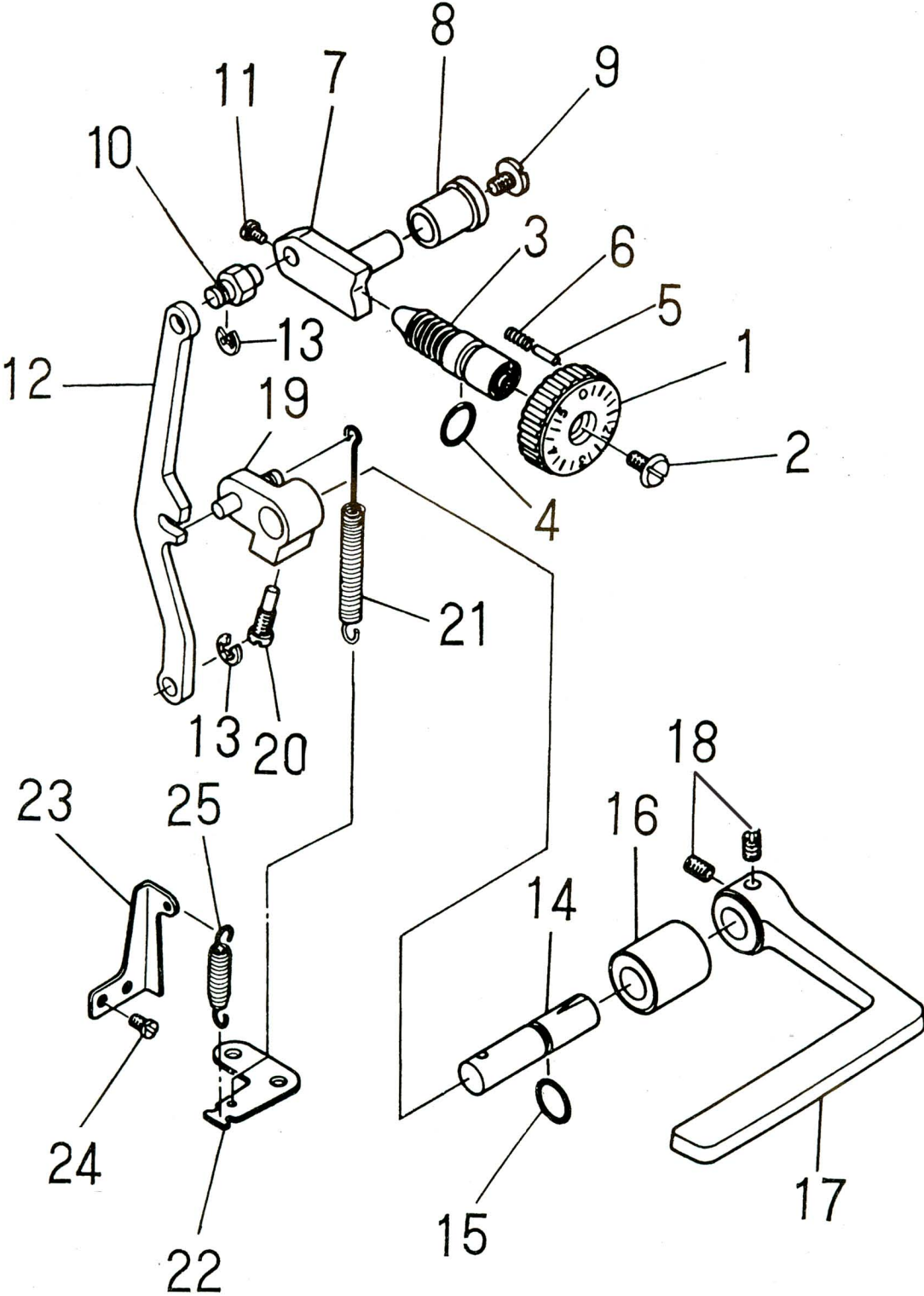

## 7. 送料调节分组件

## 7. Feed regulating components

序号 Ref. No.	件号 Part No.	名称	Description	数量 Amt.
1	10111002	送料距旋钮(8800用)	Feed dial	1
	10111019	送料距旋钮(美衣达用)	Feed dial	1
2	101S11022	螺钉 SM3/16"×28 L=18	ScrewSM3/16"×28 L=18	1
3	10426006	送料调节螺柱(8800用)	Feed regulator screw	1
	10126014	送料调节螺柱(美衣达用)	Feed regulator screw	1
4	10122016	O形圈	Rubber ring	1
5	10126015	送料距锁合销	Pin	1
6	10127010	送料距锁合簧	Spring	1
7	10401004	送料调节器(8800用)	Feed regulator	1
	10101004	送料调节器(美衣达用)	Feed regulator	1
8	10403017	送料调节器轴套(8800用)	Feed regulator bushing	1
	10103020	送料调节器轴套(美衣达用)	Feed regulator bushing	1
9	101S11023	螺钉 SM3/16"×28 L=6.5	ScrewSM3/16"×28 L=6.5	1
10	10126016	倒送料连杆销	Feed regulator pin	1
11	101S11005	螺钉 SM9/64"×40 L=6	ScrewSM9/64"×40 L=6	2
12	10405004	倒送料连杆(8800用)	Feed regulator connecting rod	1
	10105004	倒送料连杆(美衣达用)	Feed regulator connecting rod	1
13	H05009	倒送料连杆挡圈	Snap ring	2
14	10102010	倒送料轴	Feed reverse shaft	1
15	10122017	O形圈	Rubber ring	1
16	10103021	倒送料轴轴套	Feed lever metal	1
17	10101012	倒送料扳手	Reverse feed control lever	1
18	101S15013	螺钉 SM1/4"×40 L=10	ScrewSM1/4"×40 L=10	2
19	1040400500	倒送料曲柄部件(8800用)	Feed reverse arm asm.	1
	1010400500	倒送料曲柄部件(美衣达用)	Feed reverse arm asm.	1
20	101S17003	螺钉 SM1/4"×40 L=20	ScrewSM1/4"×40 L=20	1
21	10127011	倒送料拉簧	Feed reverse spring	1
22	10112018	拉簧固定板	Feed spring hook	1
23	10112019	摆动板座复位板	Adjusting link spring guide	1
24	101S11025	螺钉 SM11/64"×40 L=7	ScrewSM11/64"×40 L=7	2
25	10127012	摆动板座复位簧	Adjusting link spring	1

## 8. 润滑分组件 Lubrication components

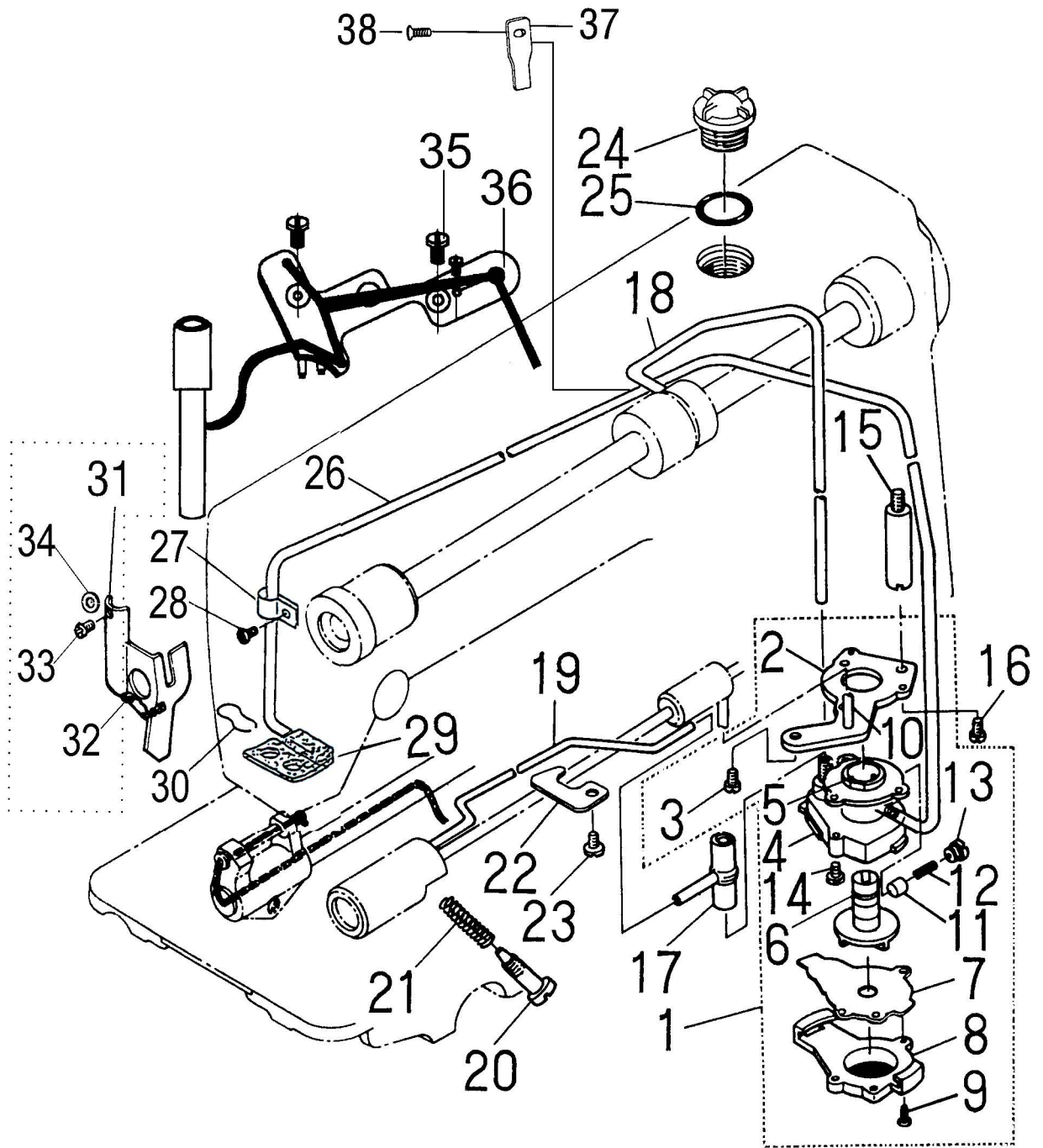

## 8. 润滑分组件

## 8. Lubrication components

序号 Ref. No.	件号 Part No.	名称	Description	数量 Amt.
1	1012000100	油泵分部件	Lubricating oil pump asm.	1
2	10112020	油泵安装板	Oil pump installing base	1
3	101S11026	螺钉 SM15/64"×28 L=9	Screw	1
4	10120001	油泵体	Oil pump	1
5	10103022	油泵体衬套	Oil pump bushing	1
6	10111003	油泵叶轮	Oil pump impeller	1
7	10112021	油泵叶轮托板	Oil pump impeller cover	1
8	10111007	油泵盖	Lubricating oil pump cover	1
9	101S30006	螺钉	Screw	1
10	10121001	下轴供油管	Hook driving shaft oil tube	1
11	10122018	回油柱塞	Plunger	1
12	10127013	柱塞簧	Plunger spring	1
13	101S30007	螺钉 SM9/32"×32 L=7	ScrewSM9/32"×32 L=7	1
14	101S11031	螺钉	Screw	3
15	101S30008	油泵连接螺柱 SM15/64"×28 L=7	Oil pump supportSM15/64"×28 L=7	1
16	101S11011	螺钉 SM11/64"×40 L=9.5	Screw	1
17	10136001	供油管接头	Rubber joint	1
18	10121005	上轴供油管	Main shaft oil tube	1
19	10121006	旋梭供油管	Oil tube	1
20	101S30009	螺钉 SM15/64"×28 L=25	Oil adjusting screw	1
21	10127014	旋梭油量调节簧	Spring	1
22	10112022	旋梭供油管压板	Tube holder(lower)	1
23	101S11026	螺钉 SM15/64"×28 L=9	Screw	1
24	10111004	油窗	Oil sight window	1
25	10122019	油窗 O 形圈	Rubber ring	1
26	10121007	回油管	Oil return tube	1
27	10112023	回油管夹	Oil return tube holder	1
28	101S11004	螺钉 SM3/16"×28 L=6	Screw	1
29	10423002	回油毡(8800 用)	Oil felt	1
	10123006	回油毡(美衣达用)	Oil felt	1
30	10127015	回油毡夹	Oil felt presser	1
31	10412001	面部防油板(8800 用)	Arm oil shield	1
	10112024	面部防油板(美衣达用)	Arm oil shield	1
32	10423004	防油板油线(8800 用)	Oil wick	1
	10123008	防油板油线(美衣达用)	Oil wick	1
33	101S11027	螺钉 SM1/8"×44 L=4	Screw	1
34	10128005	垫片	Washer	1
35	101S11010	螺钉 SM9/64"×40 L=11	Oil wick setplate screw	2
36	10112025	油线固定板组件	Oil wick setplate asm.	1
37	10112026	回油管压板	Presser	1
38	101S11033	螺钉 SM3/16"×28 L=5.8	Screw	1



9. 油盘、膝抬压脚部分组件 Oil reservoir, knee lifter components

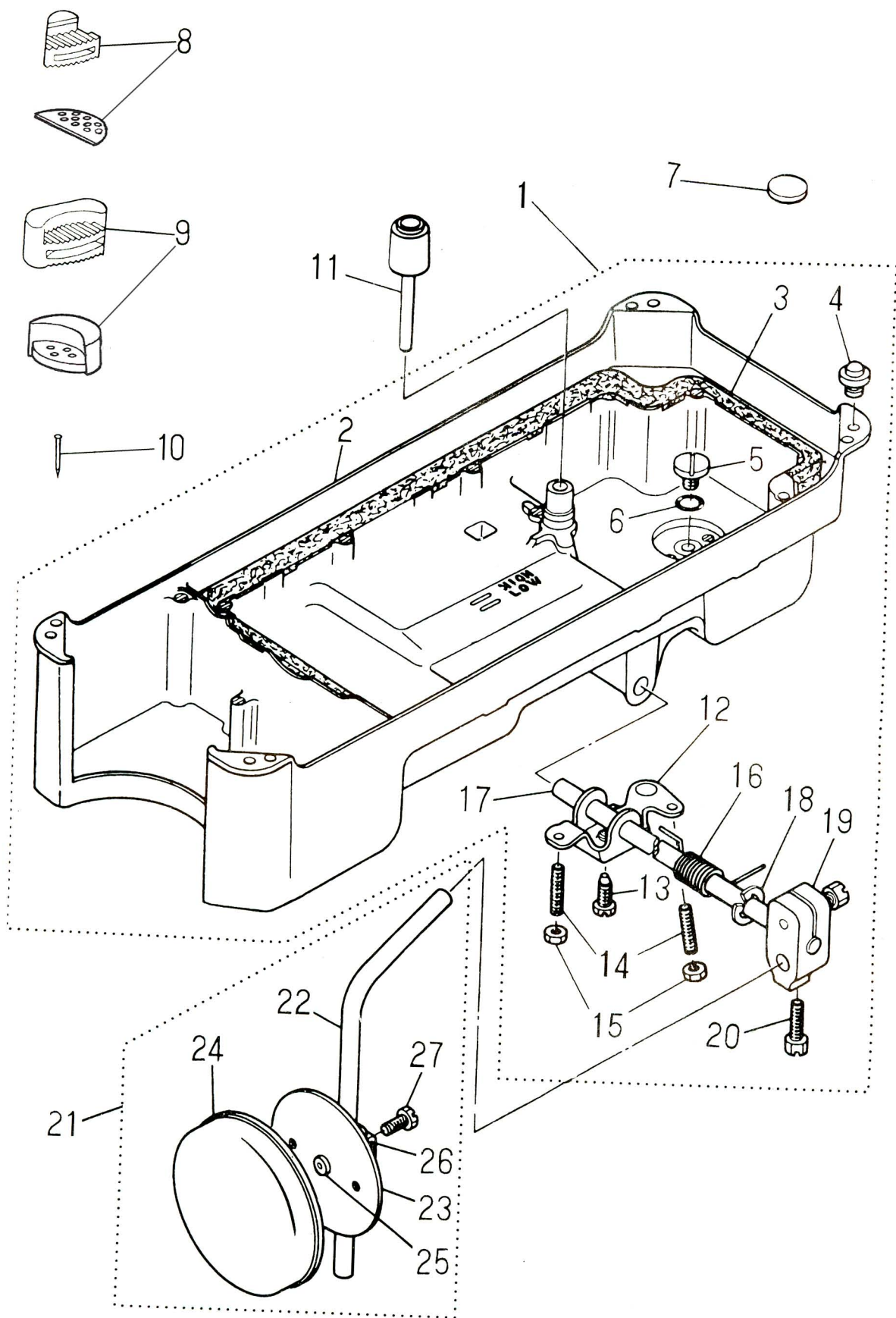

## 9. 油盘、膝抬压脚部分组件 9. Oil reservoir、knee lifter components

序号 Ref. No.	件号 Part No.	名称	Description	数量 Amt.
1	1010100600	油盘部件	Oil reservoir asm.	1
2	10101006	油盘	Oil reservoir	1
3	10122020	油盘垫	Gasket	2
	10122050	油盘垫(二)	Gasket	1
4	10122031	机头座垫(外销)	Rubber cushion	4
5	101S11028	螺钉 M8×1 L=7	Screw	1
6	10122021	O形圈	Rubber ring	2
7	10131001	油盘磁铁	Oil reservoir magnet	1
8	10122022	油盘座垫(内销)	Oil reservoir felt cushion	2
	10122032	油盘座垫(外销)	Oil reservoir felt cushion	2
9	10122023	油盘支架(内销)	Oil reservoir rubber	2
	10122033	油盘支架(外销)	Oil reservoir rubber	2
10	101S30010	油盘座钉(外销)	Nail	4
11	10111005	抬压脚顶杆	Knee press lifter rod	1
12	10112027	抬压脚双向曲柄	Connecting rod, vertical	1
13	101S12002	螺钉	Screw	1
14	101S15012	螺钉 M6 L=16	ScrewM6 L=16	2
15	101S16004	双向曲柄限位调节螺母	Net	2
16	10127016	双向曲柄扭簧	Spring	1
17	10102011	抬压脚轴	Knee press rod	1
18	H05010	抬压脚轴开口挡圈	Snap ring	1
19	10101008	抬压脚操纵杆节头	Bearing bracket	1
20	101S12003	螺钉 M8 L=12	Screw	1
21	1011202800	操纵杆部件	Knee press plate asm.	1
22	10112028	操纵杆	Knee lifter plate rod	1
23	10112029	操纵板	Knee press plate	1
24	10122024	操纵板软垫	Knee press plate cover	1
25	10122025	操纵杆垫	Rubber	1
26	10112030	操纵杆节头	Knee press plate holder	1
27	101S12004	螺钉	Screw	1

10. 机头附件 (1) Machine head accessories (1)

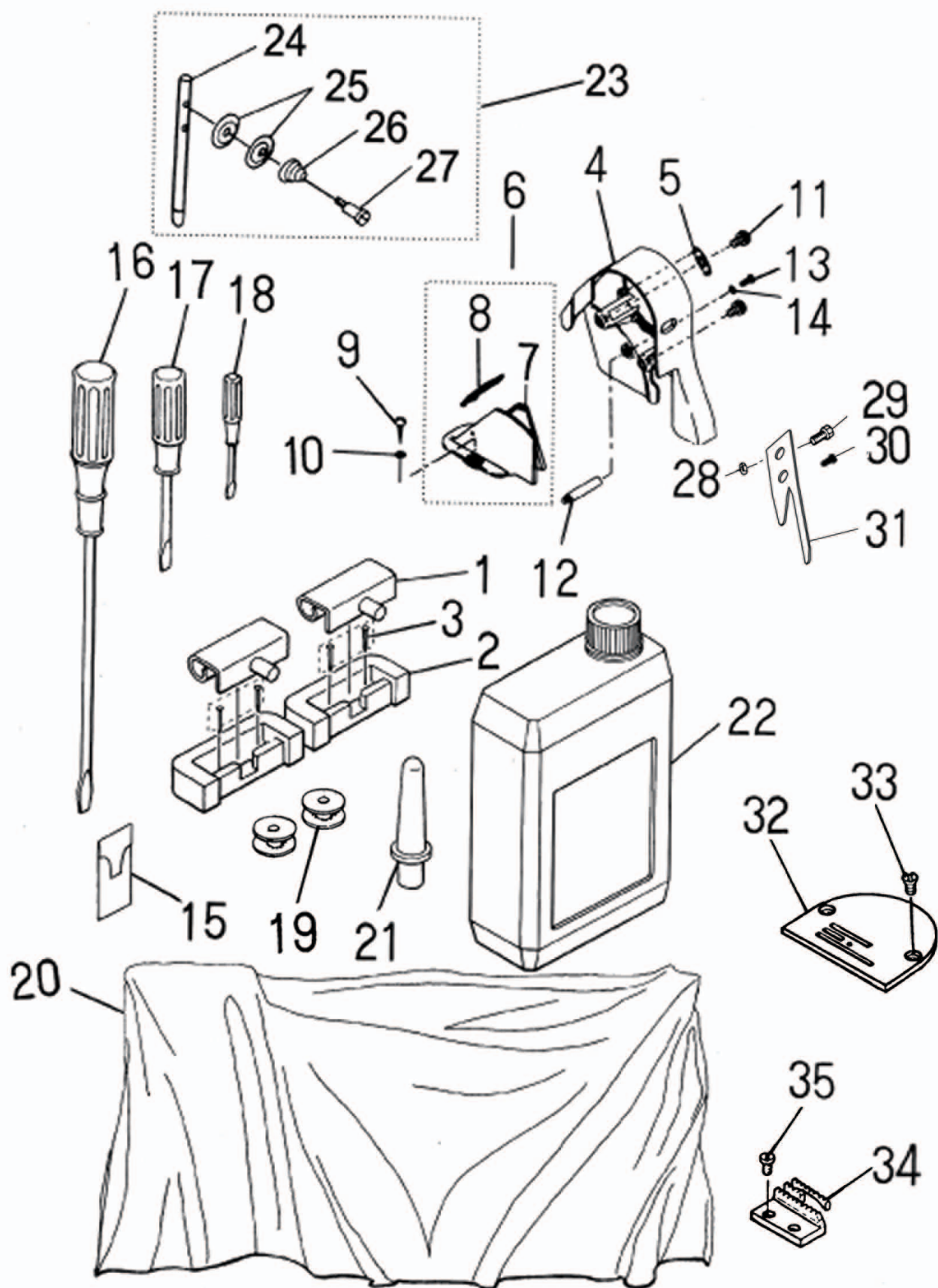

## 10. 机头附件(1)      10. Machine head accessories(1)

序号 Ref. No.	件号 Part No.	名称	Description	数量 Amt.
1	1011203100	机头连接钩部件	Machine hinge plate asm.	2
2	10122026	机头连接钩座	Machine hinge plate	2
3	101S30010	机头连接钩座钉	Nail	4
4	10111006	上轮前罩壳	Beltcover, A	1
5	10111008	前罩壳安装架	Beltcover, A cap	1
6	1011100900	上轮后罩壳部件	Beltcover, B asm.	1
7	10111009	上轮后罩壳	Beltcover, B	1
8	1011101000	后罩壳盖部件	Beltcover, B cover asm.	1
9	101S30011	木螺钉	Wood screw	2
10	10128006	垫圈	Washer	2
11	101S11029	前罩壳紧固螺钉	Beltcover, A screw	2
12	101S30012	后罩壳支柱	Beltcover support	1
13	101S11030	螺钉	Screw	1
14	10128007	垫圈	Washer	1
15	10117001	机针	Needle	1包
16	10131002	螺丝刀(大)	Screw driver, large	1
17	10131003	螺丝刀(中)	Screw driver, medium	1
18	10131004	螺丝刀(小)	Screw driver, small	1
19	10118003	梭心	Bobbin	2
20	10131005	机头罩	Machine head cover	1
21	10111011	机头支柱	Machine rest pin	1
22	1011101200	油箱部件	Oil reservoir asm.	1
23	1011300700	过线器部件	Needle thread guide pin asm.	1
24	10112008	过线柱	Needle thread guide pin	1
25	10112009	过线夹线板	Tension disc	2
26	10127004	过线夹线簧	Tension spring	1
27	101S30003	螺钉	Screw	1
28	N01006	螺母	Not	1
29	S01010	螺钉	Screw	1
30	S01044	螺钉	Screw	1
31	10419001	罩壳割线刀	Thread trimmer	1
32	10115001	针板	Throat plate	1
33	101S17002	螺钉 SM11/64"×40 L=6.4	ScrewSM11/64"×40 L=6.4	2
34	10114001	送料牙	Feed dog	1
35	101S11018	螺钉 SM1/8"×44 L=6	ScrewSM1/8"×44 L=6	2

# 10. 机头附件 (2) Machine head accessories (2)

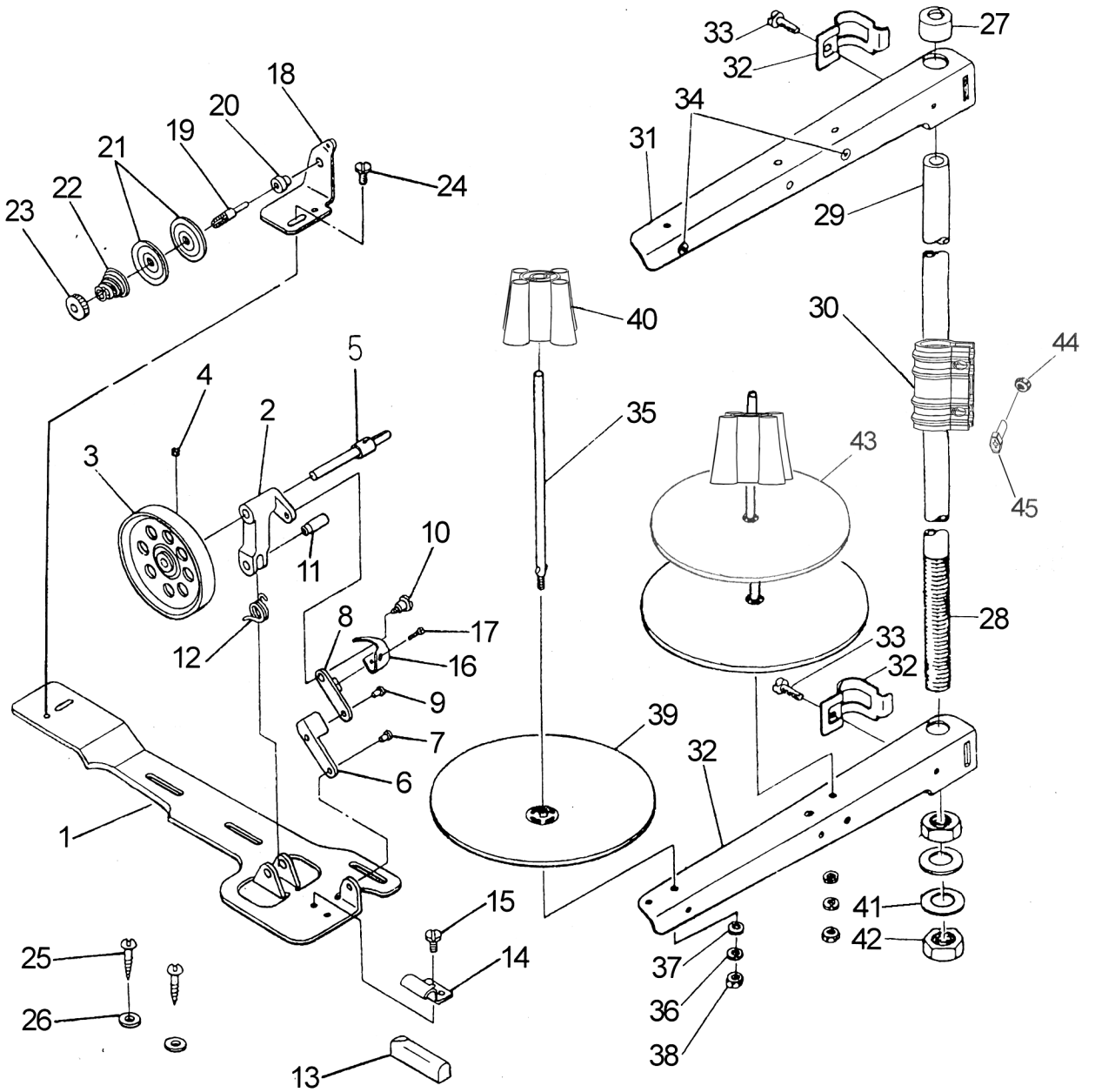

## 10. 机头附件(2)

## 10. Machine head accessories (2)

序号 Ref. No.	件号 Part No.	名称	Description	数量 Amt.
1	10112032	绕线座	Bobbin winder base asm.	1
2	10101009	绕线架	Thread winder base asm.	1
3	10101010	绕线轮	Thread winder asm.	1
4	S04006	螺钉	Screw	1
5	10102012	绕线轴	Bobbin winder shaft	1
6	10112033	绕线座连杆	Connecvting rod	1
7	10126018	绕线座连杆销	Connecvting rod pin	1
8	10112034	绕线架连杆	Bobbin winder frame rod	1
9	10126018	绕线架连杆销	Bobbin winder frame rod pin	1
10	10120006	绕线架连杆轴位螺钉	Screw	1
11	10126019	绕线架销	Bobbin winder frame pin	1
12	10127017	绕线架簧	Bobbin winder frame spring	1
13	10122027	绕线轮制动垫	Rubber brake	1
14	10112035	制动垫夹	Presser plate	1
15	S04006	螺钉	Screw	1
16	10112036	满线跳板簧	Bobbin winder spring	1
17	S04017	过线夹线螺钉	Hinge screw	1
18	10112037	过线架座	Thread tension bracket asm.	1
19	101S30013	螺钉	Screw	1
20	10108005	过线夹线板挡圈	Bobbin winder tensiom disc collar	1
21	10112038	过线夹线板	Tension disc	2
22	10127018	过线夹线簧	Tensiom spring	1
23	101S16005	螺母	Nut	1
24	S04006	螺钉	Screw	1
25	101S30014	木螺钉	Wood screw	2
26	10128008	垫圈	Washer	2
27	10122028	线架杆顶防护橡皮	Spool rest rod rubber cap	1
28	10131008	线架杆下节	Spool rest rod (lower)	1
29	10131009	线架杆上节	Spool rest rod (upper)	1
30	10112039	线架杆接头	Spool rested joint	1
31	10112040	线架过线杆	Thread guide asm.	2
32	10112041	线架过线夹	Thread guide asm joint	2
33	S04013	螺钉	Screw	2
34	10113010	过线圈	Thread guide ring	2
35	10131010	线盘钉	Spool pin	2
36	10128009	弹簧垫圈	Spring washer	2
37	101S16006	螺母	Nut	2
38	10111013	线盘	Spool rest	2
39	10111014	线团防松垫	Spool vibration stopper	2
40	10128010	垫圈	Washer	2
41	N02003	螺母	Nut	2
44	S04018	螺钉	Screw	2
45	N01002	螺母	Nut	2
46	10123008	线盘垫	Spool rest cushion	2

# 11. 机架、台板、电器分组件

Machine stand, table, electric appliance components

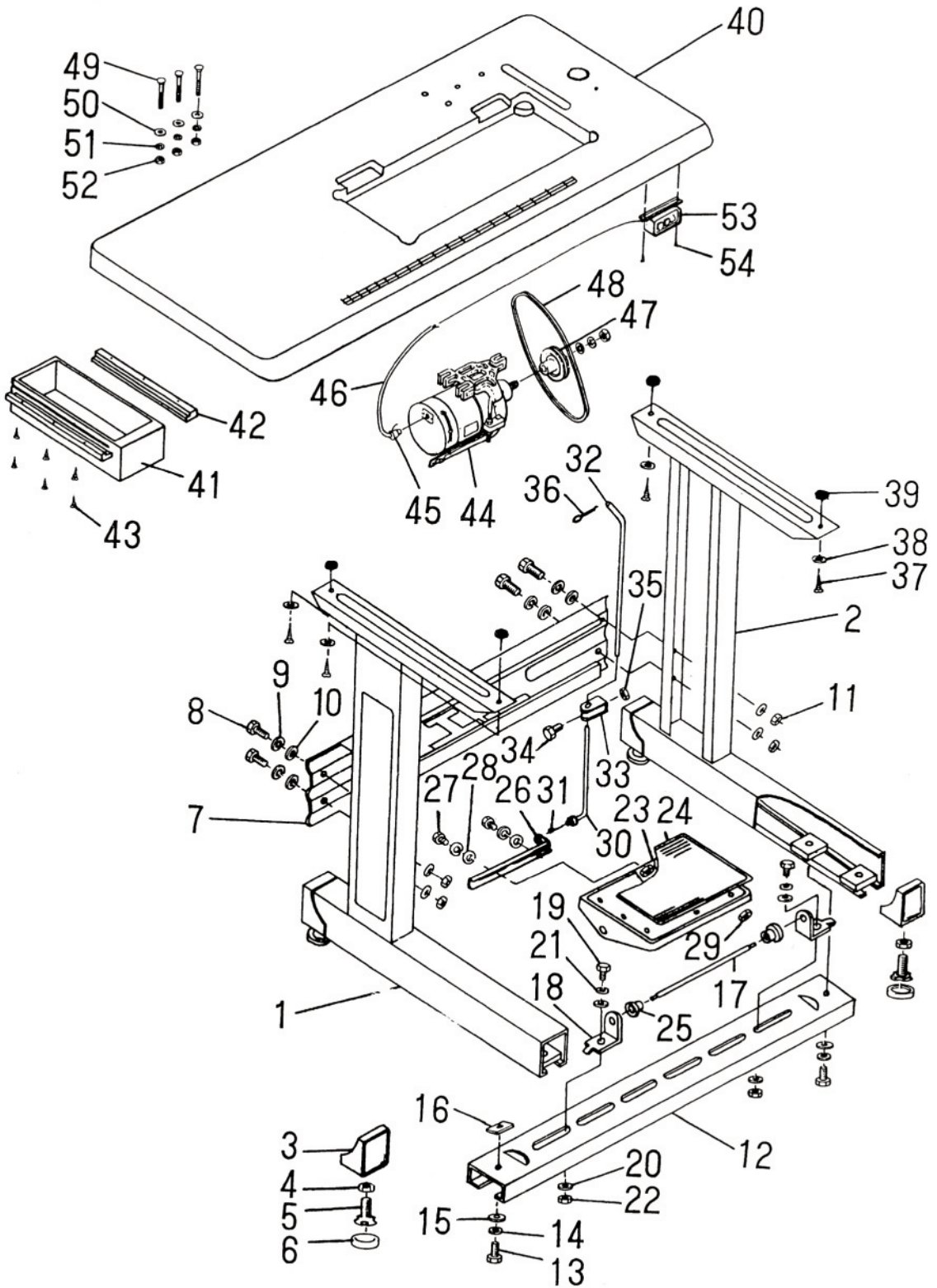

## 11. 机架、台板、电器分组件 11. Machine stand、table、electric appliance components

序号 Ref. No.	件号 Part No.	名称	Description	数量 Amt.
1	1011204200	边架部件(左)	Stand side asm. left	1
2	1011204300	边架部件(右)	Stand side asm. right	1
3	10111015	边架座套	Rubber cushion	4
4	N01010	螺母	Nut	4
5	101S30015	调节座	Screw	4
6	10122029	调节座橡胶	Space ring	4
7	10112044	横档	Stand side support	1
8	L02014	横档连接螺栓	Screw	4
9	10128011	垫圈	Spring washer	4
10	W01010	垫圈	Washer	8
11	N01011	螺母	Nut	4
12	10112045	踏板轴档	Treadle brace	1
13	L02014	踏板轴档螺栓	Screw	2
14	10128011	垫圈	Spring washer	2
15	W01010	垫圈	Washer	2
16	10112046	踏板轴档定位螺母板	Treadle brace locknut plate	2
17	10102013	踏板轴	Treadle shaft	1
18	10112047	踏板轴座	Treadle brakvet	2
19	L02014	踏板轴座螺栓	Screw	2
20	W01010	垫圈	Washer	4
21	10128011	弹簧垫圈	Spring washer	2
22	N01011	螺母	Nut	2
23	10112048	踏板	Trcable	1
24	10122030	踏板垫	Gas Ket	1
25	10103023	踏板衬套	Collar	2
26	10112049	踏板杠杆	Ttreadle pitman	1
27	L02015	踏板杠杆螺栓	Screw	2
28	W01003	垫圈	Washer	4
29	N01012	螺母	Nut	2
30	10112050	下拉杆	Pitman rod, lower	1
31	10127019	拉杆弹簧	Spring	1
32	10112051	上拉杆	pitman rod, upper	1
33	10112052	拉杆接头	Joint	1
34	L02015	拉杆接头螺栓	Joint screw	1
35	N01012	螺母	Nut	1
36	10129001	上拉杆开口销	Pitman rod split pin (upper)	1
37	101S30016	台板木螺钉	Table Wood screw	4
38	10128012	垫圈	Table Wood screw washer	4
39	10128013	台板垫圈	Table washer	4
40	10132002	台板	Table	1
41	10111016	抽斗	Drawer	1
42	10111017	抽斗导轨	Drawer rail	2
43	101S30017	抽斗导轨木螺钉	Drawer rail wood screw	6
44	10133001	GFC4024 型电机	Motor GFC4024 motor	1
45	10130002	电机接线插头	Motor connecting wire plug	1
46	10130003	电机接线	Motor wire	1
47	10135004	电动机带轮	Motor pulley	1
48	10135002	机头传动带	Machine driving beit	1
49	101S30018	螺钉	Screw	3
50	10128014	垫圈	Washer	3
51	10128011	弹簧垫圈	Spring washer	3
52	N01011	螺母	Nut	3
53	10130004	电源开关	Power source switch	1
54	101S30019	电源开关木螺钉	Power source switch wood screw	2



## 12. 厚料用

## 12. For heavy weight materials

序号 Ref. No.	件号 Part No.	名称	Description	数量 Amt.
1	1011000400	挑线曲柄分部件	Needle bar crank H asm.	1
2	10110004	挑线曲柄	Needle bar crank H	1
3	10103023	针杆下轴套	Needle bar bushing, lower	1
4	10113009	针杆下轴套线钩	Needle bar rhread guide	1
5	10102012	针杆	Needle bar	1
6	10117002	机针(DB×1#21)	Needle(DB×1#21)	1
7	10127018	调压簧	Presser spring	1
8	1011600400	活压脚板部件	Hinged presser foot asm.	1
9	10116005	活压脚板	Presser foot asm.	1
10	10116006	活压脚柄	Presser foot stem	1
11	10118505	旋梭	Hook asm.	1
12	10112032	旋梭定位钩	Positioning finger	1
13	10114002	送料牙	Feed dog(H)	1
14	10115003	针板	Thread dog(H)	1